

**HOLM CENTER T-203**

**AFROTC  
FIELD TRAINING MANUAL**



**HQ AFROTC/DO**

**1 January 2009**

Name: \_\_\_\_\_  
Detachment: \_\_\_\_\_  
FTU: \_\_\_\_\_  
Squadron: \_\_\_\_\_  
Flight: \_\_\_\_\_

## **PREFACE**

---

*“War makes extremely heavy demands on the soldier’s strength and nerves. For this reason, make heavy demands on your men in peacetime exercises.”*

-- German Field Marshall Erwin Rommel

Welcome to Field Training Preparation. This Field Training Manual (FTM) is yours to keep, and you must take it with you to Field Training (FT). Everything you need to know to prepare for the in-garrison portion of FT is included within this FTM as well as the Airman’s Manual (AFMAN 10-100). Although you will be provided additional instructions upon deployment to Blue Thunder (BT) and Camp Shelby Joint Forces Training Center (CSJFTC), you will be responsible for the content of this manual for the entire duration of FT. You may write in, highlight, or underline it as desired. Ensure you have a thorough understanding of this material prior to departing for your Field Training Unit (FTU); you will be held accountable upon arrival.

Field Training is a mandatory program for all individuals qualified to pursue an Air Force commission through AFROTC. *The program is designed to evaluate military leadership and discipline, determine your potential for entry into the professional officer corps, and stratify you among your peers.*

FT is conceived as a mock Air and Space Expeditionary Force (AEF) deployment, and is therefore designed in line with the Airman’s Manual (provided to you hard copy by your detachment and online at <http://www.e-publishing.af.mil/pubfiles/af/10/afman10-100/afman10-100.pdf>). For this reason, all cadets attending FT will be required to demonstrate familiarity with any and all sections of the Airman’s Manual at any point during the FT experience. Please reference Attachment 1, FTU Training Phases by Training Day, for the sections of the Airman’s Manual cadets will most likely utilize during particular phases of FT. Keep in mind that this is not a hard-and-fast agenda, FTU staff may adjust the timeline when required or when deemed prudent and necessary for the attainment of FT goals.

The sections and/or paragraphs of this FTM are identified by three different levels of understanding--Knowledge, Familiarization and Information.

Knowledge: These sections will be indicated by a **(k)**. You will memorize and demonstrate proficiency in these areas and will be required to take a closed-book test on the information.

Familiarization: These will be indicated by an **(f)**. You will not be required to memorize the information, but will be held accountable for finding the information when necessary.

Information: These sections will be indicated by an **(i)**. These areas are for informational purposes only, you will not be required to memorize the information and will not be tested on it.

Your detachment staff will provide you with orders, tickets, uniforms and other items, which you are required to take to FT. You'll need to keep two copies of your orders with you at all times. Before you depart, provide your family with a copy of your orders, scheduled departure times and return times, and the FTU address and phone number (annotated within this document).

Cadets who have not completed the AFROTC AS 100 and AS 200 courses at their detachments will be required to attend extended FT, or Field Training Academic Preparation (FTAP). The FTAP cadets will arrive in Atlanta and be bussed to an off-site location for five days of intensive academics as well as FT preparation in such areas as physical fitness, drill and ceremonies, dress and appearance, and customs and courtesies. While at FTAP, these cadets will report administratively to the AFROTC/DOT for any questions, concerns, or issues that may arise. At the conclusion of FTAP, these cadets will arrive at Maxwell AFB on Training Day (TD)-1 to join the rest of the cadets at their FTU.

Advise your family that if an emergency should arise, the best way to contact you is through the detachment for general information or the American Red Cross. This method is usually faster than a telegram or personal phone call and will provide official verification of the emergency. Also, it is extremely important that prior to departing for FT, you verify and update your emergency data (name and address of next of kin) with your detachment personnel.

Cadets are **not** allowed to have visitors while in garrison, at BT, or at CSJFTC. Advise both family and friends they will **not** be allowed to visit with you while assigned to the FTU. This includes religious services and the final parade. If you have family or friends within the immediate area (to include stationed on or visiting Maxwell AFB or CSJFTC) or have family or friends traveling to the area, it is your responsibility to inform them they will **not** be allowed to see you or

interact with you until you are released from training the morning of TD -28.

Cadets traveling on commercial aircraft will wear short sleeve blues with black combat boots or black low quarters, no ribbons or badges. These cadets must bring one complete Air Force Physical Training Uniform (PTU) and personal hygiene items in a backpack/carry-on bag. Your issued duffle bag and a backpack/carry-on (must conform to AFI 36-2903) is the only authorized luggage. In accordance with TSA guidance, you must have an identification tag attached to your luggage.

**Do not write on or mark the duffle bag.**

In the event you arrive ahead of your luggage, having both uniforms will help your transition until your 'checked' luggage arrives.

If you have any questions about FT or the FTM, your detachment staff will be happy to assist. Keep in mind you are preparing for commission in the world's finest Air Force ... stay motivated and good luck!

## ***TABLE OF CONTENTS***

---

Preface .....	3
Table of Contents .....	6
<b>CHAPTER 1: WARRIOR KNOWLEDGE</b>	
1. Warrior Knowledge .....	9
<b>CHAPTER 2: PAY AND TRAVEL</b>	
1. Pay .....	13
2. Travel .....	13
3. Commercial Travel Luggage Instructions .....	17
4. FTU Contact Information .....	17
5. Settlement .....	17
<b>CHAPTER 3: UNIFORMS, CLOTHING, AND SUPPLIES</b>	
1. General Guidelines .....	19
2. Uniform Requirements .....	20
3. Additional Required Items .....	20
4. Optional Items .....	21
<b>CHAPTER 4: MEDICAL TREATMENT AND FIRST AID</b>	
1. Medical Treatment and Medicines .....	25
2. Heat Stress .....	27
3. First Aid .....	27
<b>CHAPTER 5: FIELD TRAINING ORGANIZATION</b>	
1. Overview .....	31
2. Field Training Staff .....	31
3. Cadet Training Assistants .....	32
4. Cadet Organization .....	32
5. Cadet Leadership Responsibilities .....	33
6. Cadet Positions .....	33
7. Cadet Position Descriptions .....	34
<b>CHAPTER 6: HONOR CODE AND PROFESSIONAL VALUES</b>	
1. The Cadet Honor Code .....	39
2. Core Values .....	39
<b>CHAPTER 7: RULES AND REGULATIONS</b>	
1. Discipline .....	41
2. Prohibitions .....	41
3. Tattoos .....	43
4. Drugs and Alcohol .....	43

5. Information Management Tools (IMT).....	43
6. Military Decorum .....	44
7. Discrimination and Sexual Harassment .....	52
8. Property Security.....	52
9. Government Property.....	53

**CHAPTER 8: GENERAL ACTIVITIES**

1. Daily Schedule .....	54
2. Call-To-Quarters (CTQ).....	54
3. Lights Out .....	55
4. Signing Out/In .....	55
5. Formations .....	55
6. Road Guard Procedures .....	57
7. Guidon Procedures .....	58
8. Building Entrance and Departure Procedures .....	59
9. Religious Accommodations .....	60
10. Individual Cadet Time (ICT).....	61
11. Telephones .....	61
12. Mail .....	61

**CHAPTER 9: DINING FACILITY PROCEDURES**

1. General Information .....	62
2. Entrance Procedures .....	62
3. Dining Facility Procedures .....	64
4. Departure Procedures .....	67

**CHAPTER 10: DORMS AND BAYS IN GARRISON**

1. General Information .....	69
------------------------------	----

**CHAPTER 11: DORMS AND BAYS MAINTENANCE**

1. Beds – General Guidelines .....	71
2. AFROTC IMTs 84M / IMT 84M-1.....	75
3. Closet .....	75
4. Shoe Display .....	79
5. Security Drawer .....	81
6. Personal Hygiene Drawer.....	81
7. Clothing Drawers.....	82
8. Bed Drawers.....	84
9. Special Displays .....	86
10. Supplemental Information.....	88

**CHAPTER 12: INSPECTIONS/EVALUATIONS/COUNSELING**

1. Introduction .....	90
2. Formal Inspections .....	90
3. Inspection Guidelines .....	93
4. Informal Inspections .....	94
5. Drill Evaluations .....	94
6. Evaluation .....	95
7. Counseling .....	95

**CHAPTER 13: PHYSICAL TRAINING (PT)**

1. Overview.....	97
2. Qualifying Fitness Review (QFR).....	97
3. PT Sessions .....	97
4. PFA.....	98
5. Conduct of the PFA .....	99

**CHAPTER 14: FIELD TRAINING COMPLETION**

1. Requirements .....	102
2. Non-Completion .....	102

**CHAPTER 15: AWARDS**

1. Individual Field Training Awards.....	104
2. Field Training Flight Awards.....	105

**ATTACHMENTS:**

1. FTU Training Phases.....	107
2. LCE .....	108
3. FTPR.....	110
1. AETCVA 36-3, <i>Sexual Harassment</i> .....	111
2. Acronyms .....	112
3. Standards of Behavior.....	114
4. Drill Evaluation .....	117

## ***CHAPTER 1: WARRIOR KNOWLEDGE (k)***

---

**1. WARRIOR KNOWLEDGE** All cadets will be required to demonstrate knowledge of the following information and repeat it verbatim when questioned by FTU staff.

**a. USAF Chain of Command:**

President: Barack H. Obama  
Sec of Defense: Robert M. Gates  
Sec of the Air Force: Michael B. Donley  
USAF Chief of Staff: Gen Norton A. Schwartz  
AETC/CC: Gen Stephen R. Lorenz  
AU/CC: Lt Gen Allen G. Peck  
Holm Center/CC: Brig Gen Teresa A. H. Djuric  
AFROTC/CC: Col Jonathan McCain

**b. USAF Major Commands:**

- (1) Air Mobility Command: Scott AFB, IL
- (2) Air Combat Command: Langley AFB, VA
- (3) Air Education & Training Command: Randolph AFB, TX
- (4) Air Force Space Command: Peterson AFB, CO
- (5) Air Force Special Operations Command: Hurlburt Field, FL
- (6) United States Air Forces in Europe: Ramstein AB, Germany
- (7) Pacific Air Forces: Hickam AFB, HI
- (8) Air Force Materiel Command: Wright-Patterson AFB, OH
- (9) Air Force Reserve Command: Robins AFB, GA

**c. Important Quotes to Know:** *Note: cadets are also required to memorize the quotes appearing at the end of each chapter.*

Duty then is the sublimest word in the English language. You should do your duty in all things. You can never do more. You should never wish to do less.

Gen Robert E. Lee

The American people rightly look to their military leaders to be not only skilled in the technical aspects of the profession of arms, but to be men of integrity.

Gen Joseph L. Collins

Leadership is intangible; therefore no weapon ever designed can replace it.

Gen Omar Bradley

If our air forces are never used, they have achieved their finest goal.  
Gen Nathan Twining

If I didn't have air supremacy, I wouldn't be here.  
Gen Dwight D. Eisenhower

## d. *The Air Force Song*

Off we go into the wild blue yonder,  
Climbing high into the sun;  
Here they come zooming to meet our thunder,  
At 'em boys, Give'er the gun!  
Down we dive, spouting our flame from under,  
Off with one helluva roar!  
We live in fame or go down in flame. Hey!  
Nothing'll stop the U.S. Air Force!

Minds of men fashioned a crate of thunder,  
Sent it high into the blue;  
Hands of men blasted the world asunder;  
How they lived God only knew!  
Souls of men dreaming of skies to conquer  
Gave us wings, ever to soar!  
With scouts before And bombers galore. Hey!  
Nothing'll stop the U.S. Air Force!

Here's a toast to the host  
Of those who love the vastness of the sky,  
To a friend we send a message of his brother men who fly.  
We drink to those who gave their all of old,  
Then down we roar to score the rainbow's pot of gold.  
A toast to the host of men we boast, the U.S. Air Force!

Off we go into the wild sky yonder,  
Keep the wings level and true;  
If you'd live to be a gray-haired wonder  
Keep the nose out of the blue!  
Flying men, guarding the nation's border,  
We'll be there, followed by more!  
In echelon we carry on. Hey!  
Nothing'll stop the U.S. Air Force!

e. ***THE AIRMAN'S CREED***

I AM AN AMERICAN AIRMAN.

I AM A WARRIOR

I HAVE ANSWERED MY NATION'S CALL.

I AM AN AMERICAN AIRMAN.

MY MISSION IS TO FLY, FIGHT AND WIN.

I AM FAITHFUL TO A PROUD HERITAGE,

A TRADITION OF HONOR,

AND A LEGACY OF VALOR.

I AM AN AMERICAN AIRMAN,

GUARDIAN OF FREEDOM AND JUSTICE,

MY NATION'S SWORD AND SHIELD,

ITS SENTRY AND AVENGER.

I DEFEND MY COUNTRY WITH MY LIFE.

I AM AN AMERICAN AIRMAN:

WINGMAN, LEADER, WARRIOR.

I WILL NEVER LEAVE AN AIRMAN BEHIND,

I WILL NEVER FALTER,

AND I WILL NOT FAIL.

## ***CHAPTER 2: PAY AND TRAVEL (i)***

---

### **1. PAY**

**a.** All cadets are paid at the same rate per training day. Pay starts on TD-1 and ends on the last day of FT or the day you are released from FT. You must have a checking account and an SF Form 1199A, *Direct Deposit Sign-up Form*, on file at your detachment to receive FT pay.

**b.** Your pay is income and therefore subject to Federal Income Withholding and Social Security taxes (FICA). Exemption from withholding of federal income taxes is authorized only if you have completed a Form W-4, *Employees Withholding Allowance Certificate*, which states you had no income tax liability in the prior tax year and expect none for the current tax year. A TD Form W-2, *Wage and Tax Statement*, will be mailed to you no later than 31 January of the next year. Be sure to keep this form, as you will be required to file it with your annual tax return.

**c.** Servicemen's Group Life Insurance (SGLI) basic coverage is available for cadets who attend FT provided that they sign-up for this at their detachment prior to departing for FT. Forms must be completed at your detachment before you depart for FT. If you sign up, you will automatically receive the maximum amount of coverage (\$400,000). You may, however, elect to decline SGLI or opt for a reduced coverage. Coverage can be reduced from \$400,000 to any amount using \$10,000 increments.

### **2. TRAVEL**

**a.** Because FT attendance is mandatory for an AFROTC commission, the Air Force will pay for your travel to and from FT. Regardless of the mode of travel, scholarship cadets will receive a pro rata share of the current per diem payment based on travel time. Cadets may also be reimbursed for mileage to and from the airport, bus, or rail terminal. Cadets will be issued a duffle bag. This bag and a carryon/backpack (which conforms to AFI 36-2903) are the only authorized luggage items.

**b.** Cadets will travel in blues and wear black combat boots or black low quarters. If cadets only have sage combat boots, they **must** travel in low quarters.

c. Your travel orders direct you to travel from a specified point of departure (POD) to Maxwell AFB base and, upon completion of training, return to the same POD. Your detachment is only authorized to procure airline travel that originates from either your home of record or your detachment location.

**(1) AIR TRAVEL.** Air transportation is the normal mode of travel if the POD is 150 or more miles away from your assigned FTU and 150 or more miles away from the airport hub (Atlanta International for Maxwell) servicing your FTU. AF Reserve members are authorized to travel by military aircraft on a space-available basis; however, they are not authorized travel pay for that portion of travel.

(a) Your detachment will provide electronic airline tickets and a flight itinerary. Once you receive these items, verify the information to ensure complete round trip travel to and from the correct locations. Contact the airport for recommended arrival times. Commercial airlines have strict baggage codes. You will be responsible for any excess baggage costs. You should only have a backpack/carry-on bag and your issued duffel bag.

(b) If you lose your itinerary, contact your detachment for a copy.

(c) You will be issued electronic tickets. You must contact the designated airline, confirm your reservation, and ensure the ticket is paid for NLT 5 days prior to your departure. If the airline has no reservation or the ticket is not paid for, contact your detachment staff immediately. Report to the airline counter at least 2 hours prior to your scheduled flight.

(d) Overseas transportation will be provided only for cadets who reside in Alaska, Hawaii and US territories (Puerto Rico, Guam, Virgin Islands, or American Samoa) or whose sponsor is active duty military on PCS orders. Otherwise, cadets traveling from overseas will receive government provided transportation from and to the same port-of-entry. Any remaining travel expenses (to include lodging) will be at the cadet's expense. Cadets traveling from overseas locations must plan accordingly for proper rest and nutrition when traveling to FT.

**(e) Ensure your flight into Atlanta will arrive no later than 1400 hours on your arrival day.** In the event your flight to FT is rescheduled, contact your detachment staff immediately. They will coordinate with HQ and the FTU staff accordingly. **DO NOT**

volunteer to be bumped from your scheduled flight to FT under any circumstances.

(f) Cadets with PODs less than 150 miles from Atlanta must be dropped off at the airport via automobile, bus, or rail. Overnight parking is not authorized.

(g) When you fly into Atlanta, retrieve your baggage from the claim area and immediately report to the designated AFROTC check-in desk. Listen for pages announced over the airport public address system and follow signs. You will then travel by charter transportation to the FTU. Prior to departing to the FTU, call home one final time to let your loved ones know you arrived safely. Ensure you have sufficient funds or means to make this telephone call. Telephones are off-limits upon arrival at the FTU.

(h) Following FT, cadets will return to their POD only. **No itinerary changes will be authorized.** EXCEPTION: FTU staff will facilitate changes, as necessary, for cadets released or removed early from the FTU.

(i) YOU MUST RETURN ANY UNUSED TRAVEL TICKETS. Turn these in to detachment staff as soon as possible; include a copy of your travel voucher.

**(2) BUS/RAIL TRAVEL.** Bus or rail transportation is reserved for cadets whose POD is less than 150 miles from their FTU or less than 150 miles from the servicing airport hub (Atlanta).

(a) Your detachment will provide you with bus/rail tickets, a travel itinerary, or a Government Transportation Request (GTR), which is similar to a certified check. If you receive a GTR, it is your responsibility to secure your tickets at the terminal. As with airline tickets, bus/rail tickets and the GTR are your responsibility. If they are lost or stolen, you will have to replace them at your own expense. Verify all travel information to **ensure you will arrive no earlier than 1200 and no later than 1400 hours.** If your tickets indicate you will arrive after 1400, notify your detachment immediately to facilitate a change.

(b) Bus and rail lines have strict baggage codes. Contact your carrier to inquire about baggage restrictions. You will be responsible for any associated costs for exceeding baggage restrictions. Arrive at least 1 hour prior to your scheduled departure.

(c) An AFROTC representative will be at the terminal to transport you to your FTU. If an AFROTC member is not present, contact your FTU immediately to announce your arrival. Prior to departing the terminal, you should call home one final time to let your loved ones know you arrived safely. Ensure you have sufficient funds to make this telephone call. Telephones are off-limits upon arrival at FT.

**(3) POV TRAVEL.** POV travel is not encouraged and is **only authorized** for cadets whose POD is less than 150 miles from Maxwell AFB or less than 150 miles from the servicing airport hub. If driving or riding in a POV, you must notify your detachment and coordinate your anticipated arrival date and time.

(a) If traveling by POV, **you should arrive at the FTU not earlier than, but as close as possible to 1200 hours on the authorized travel day. Arrive no later than 1400 hours local time.** Plan accordingly for time to obtain a base pass. If you arrive prior to the authorized travel day, you will be responsible for your own accommodations.

(b) Any incidents (accidents, tickets, etc.), which occur while traveling to FT, must be reported during in-processing. Incidents while traveling from FT must be reported to your detachment. You should be prepared to provide the following information:

1. The location and time of the incident.
2. The name and address of other person(s) involved.
3. The name and address of any witness.
4. The tag number and make of the vehicle(s) involved.
5. Any other pertinent details concerning the incident.

(c) You should call home one final time prior to entering the base to let your loved ones know you arrived safely at FT. Telephones are off-limits upon arrival at FT.

(d) Driving on base is a privilege and you must satisfy all requirements prior to being allowed to enter the base. You must bring a valid driver's license, proof of automobile insurance (minimum requirement for the state in which automobile is registered), state vehicle registration, and if the vehicle is not yours, you must have notarized, written permission from the vehicle owner.

(e) Your POV will be parked in a designated area and locked during FT. Do not leave items of value where they can be seen. You may want to purchase a sunscreen or car cover to prevent heat damage to the interior.

(f) You must turn-in your car keys during in-processing; they will be secured with your Flight Commander (FLT/CC) for the duration of FT. Your POV is off-limits during FT.

(g) You will be reimbursed at either the current mileage rate or the cost of the government ticket (whichever is less). However, you will not be reimbursed for mileage if you are a passenger in an auto or aircraft operated by another individual (active duty, cadet, etc.) who will receive travel allowances.

(h) Do not check in at the billeting office. Your quarters will be assigned during in-processing at the FTU. Cadets will report to Ritchey Center, Bldg 1425.

### **3. COMMERCIAL TRAVEL LUGGAGE INSTRUCTIONS.**

Mark your luggage on the outside with the following example: **Cadet (your name), AFROTC, Bldg 1487, Maxwell AFB, AL 36112**. If your luggage is lost upon your arrival, contact your carrier and complete a lost luggage form and request delivery to the same address.

**4. FTU CONTACT INFORMATION.** If you have any problems en route to FT, contact your FTU at (334) 953-9675.

**5. SETTLEMENT.** Only Scholarship/Contract cadets will receive travel per diem to/from FT. Scholarship cadets must follow the below instructions to receive travel pay and mileage to/from airport or FTU. Non-scholarship cadets may submit travel vouchers for mileage to/from airport or FTU and meals eaten on travel days (must have receipt for meals).

**a.** Make all your pay entitlements known to the SDCS in sufficient time to be resolved before you depart from the FTU. If you are unsure about any money matters, discuss them with the SDCS section. Also, inform the SDCS section of any terminal mileage (travel from your house to the airport, rail or bus station and back) that should be reimbursed. Make sure you keep all receipts during your travel for reimbursement.

**b.** You will receive a DD Form 1351-2, *Travel Voucher or Sub-voucher*, and detailed instructions on how to complete the form. You must attach all your receipts, any unused tickets, four (4) copies of your

orders, and a copy of a deposit slip or voided check (for direct deposit requests) to the DD Form 1351-2, which will be completed when you return home.

(1) THE DD FORM 1351-2 MUST BE COMPLETED IN ORDER FOR YOU TO RECEIVE ALL YOUR TRAVEL PAY ENTITLEMENTS.

(2) The completed voucher must be mailed or hand-carried to your detachment within 10 business days of returning home – do not wait until you return to school for the fall term.

## ***CHAPTER 3: UNIFORMS, CLOTHING, AND SUPPLIES (i)***

---

**1. GENERAL GUIDELINES.** Your detachment will issue all uniform items needed for FT. Other items will be issued to you at FT. All issued (uniform and equipment) items are your responsibility; you will be liable for their replacement. You will be required to bring certain additional items at your own expense.

**a. Civilian Clothing.** Cadets should bring one set of civilian clothes to FT. Cadets attending FTAP are encouraged to bring three sets of civilian clothing for wear during their week of Academic Preparation held off-site. All cadets will put their civilian clothing in storage upon arrival to FT on Maxwell AFB.

**b. Grooming Standards.** All cadets must comply with AFI 36-2903 and AFROTCI 36-2008, *AFROTC Cadet Uniforms and Insignia*.

(1) Exception: Mustaches will not be authorized while at FT.

(2) Per regulation, make-up is unauthorized in field conditions, specifically BT and CSJFTC. It is recommended that cadets do not bring make-up to FT.

(3) Each cadet must maintain his/her personal hygiene and shower at least once per day whether in garrison, at BT, or at CSJFTC. Showers are mandatory whenever Personal Hygiene (PH) time is scheduled, and cadets must wash hands after using the latrine. All cadets will change undergarments each day and will not wear uniforms more than two days without washing them while in field conditions. Laundry rooms are available on each floor of cadet dormitories while in garrison and laundry service will be provided while at BT and CSJFTC. Cadets are responsible for implementing a laundering schedule amongst flights and squadrons while in garrison and arranging laundry pick-up and drop-off (within provided scheduling guidance) while at BT and CSJFTC.

(4) Each cadet must mark all undergarments, towels and washcloths with a **permanent clothing marker** to ensure proper hygiene. Mark clothing using the following convention: first letter of last name followed by last four digits of your social security number (for example, P1234).

**c. Uniforms.** Military uniforms must be worn in accordance with AFI 36-2903, *Dress and Personal Appearance of Air Force Personnel*, and AFROTCI 36-2008, *AFROTC Cadet Uniforms and Insignia*.

**d. Caps.** All caps must be clean and fit properly.

(1) When not worn or stored, flight caps will be tucked under the left side of the belt between the first and second belt loops. The cap will be flush with the top edge of the belt, on the left side of the body, with the open end of the cap facing the pocket.

(2) The BDU/ABU cap will be placed inside the left cargo pocket if not being worn. The cap will not be visible while in the pocket. BDU/ABU caps **WILL NOT** be worn with the PT uniform.

**e. Camelbak.** A full Camelbak canteen is always worn with BDUs/ABUs and PTUs unless otherwise directed.

(1) While in *blues*, carry the Camelbak in the left hand.

(2) When sitting, store your Camelbak under the seat and even with the front of the chair.

**f. Accessories.** Sunglasses are not authorized at FT. Prescription photosensitive lenses are acceptable for all activities during FT per AFI 36-2903, Table 2.6, Item 6.

**g. Sleepwear.** As a minimum, your sleepwear will consist of the PT shorts and PT T-shirt. Cadets may wear flip-flops in the dorms in the evening at FLT/CC or CTA discretion.

**h. Jewelry.** In the interest of safety, jewelry will not be worn at any time with the following exceptions: medical alert necklaces/bracelets and wedding rings/bands. These items must be worn in accordance with AFI 36-2903. Store jewelry in the personal area of the security drawer while in garrison (Chapter 9) and locked in your duffle bag while in the field (it is highly recommended that you do not bring any jewelry). FLT/CCs will prescribe the activities during which watches may be worn and the individual(s) who may wear them. Hourly chimes and alarms on watches will be turned off at all times.

**2. UNIFORM REQUIREMENTS.** Make sure your uniforms are serviceable, fit properly, and are free of cables (loose strings). **Ensure your athletic shoes and boots are broken in to prevent blisters.** Blisters are one of the main reasons cadets miss training. Uniform requirements are listed in Field Training Uniform and Equipment Checklist (AF IMT 2519 V5).

**3. ADDITIONAL EQUIPMENT AND PERSONAL ITEMS.** These items are listed on the AF IMT 2519 V5. They **are required**

and must be purchased at your own expense – your detachment will not provide them (exception: *Field Training Manual and Airman’s Manual*). You should also bring at least \$75 to defray any personal expenses. If you are attending one of the academic sessions (extended FTUs), you should plan to bring a minimum of \$100. **Additionally, bring two mouth guards already boiled and sized.**

**4. OPTIONAL ITEMS.** The following items are not required but may be brought for your convenience.

**a. Eyeglasses.** Constraints on time and concerns regarding field-condition sanitation make proper care of contacts difficult, therefore contacts are **not** authorized during any portion of FT. It is highly recommended that cadets do not bring contacts to FT. Cadets who require vision correction must bring **two** pairs of eyeglasses that conform to AFI 36-2903. Note: If you bring eyeglasses to wear at FT you must bring an eyeglass strap to secure them during physical activities. Straps must be black or dark blue and free of any advertisements or logos and must also conform to AFI 36-2903.

**b. Athletic Shoes (second pair).** Highly Recommended.

**c. Personal Hygiene and Miscellaneous Items.** These are also listed in the AF IMT 2519 V5. Your detachment can provide you with this form.

	<b>Blues Uniform Items</b>
4	Socks, cotton, black (2 pair issued, 2 pair personal expense)
2	Trousers (male)/slacks (female), polywool
1	Belt, blue, w/chrome like finish on clip and matching buckle
2	Shirt (male/blouse (female, tuck-in only), short sleeve w/epaulets
3	T-shirt, white, v-neck (3 personal expense)
2	Name tag, plastic, ultramarine blue
2	Rank, cadet, third class set (soft)
1	Cap, flight, w/silver and blue diamond pattern edge braid
1	Jacket, blue, lightweight w/liner (optional)

1	Shoes, low quarters, black
	<b>Utility Uniform Items (BDUs/ABUs)</b>
1	Boots, combat, black or sage green w/ ABUs
1	Cap, BDU or ABU
6	Socks, wool, black (BDUs)/sage green (ABUs) (2 pair issued, 4 pair personal expense)
3	Trousers, BDUs or ABUs
1	Belt, blue w/black clip and matching buckle/Desert Rigger belt sand-colored (ABU)
6	Undershirt, brown (BDU)/sand (ABU), crew neck (3 issued, 3 personal expense)
3	Shirt, BDU or ABU with name and USAF tapes
2	Rank, cadet, third class set (metal)
	<b>PTUs (1 ea shirt, shorts, socks, athletic shoes, shall be in carry-on)</b>
4	PT uniform shirt, Air Force
4	PT uniform shorts, Air Force
8	Socks, plain white, below-the-calf (8 personal expense)
1	Shoes, athletic, running, lace-up (personal expense)
3	Towel, white (approximately 24" x 14") (3 personal expense)
	<b>Other clothing/personal items (all items at personal expense)</b>
1	Civilian slacks and shirt (1 ea; FTAP cadets 3 ea)
8	Underwear (male/female)
6	Bra (female) (any combination of bras/sports bras)
2	Mouth guards (prefit)
1	Shoeshine kit (equipment and supplies)
1	Kneepads (optional) for field exercises, black, sage green or tan
	<b>Bathing and hygiene items (all items at personal expense) (bring a 30 day supply)</b>
1	Razor (w/additional blades) or electric razor

1	Shaving cream (unless bringing electric razor)
1	Toothbrush and toothpaste
1	Aftershave (optional)
1	Shampoo
1	Comb or brush
1	Shower clogs (flip-flops) or slippers
1	Soap (bar w/soap box, or liquid soap)
3	Towel, white, bath (approximately 54" x 32")
3	Washcloth, white (approximately 12" square)
4	Storage bags, Zip-Loc type, quart size
	<b>Safety and sanitary items</b> (all items at personal expense) (bring a 30 day supply)
1	Hand sanitizer, liquid
1	Insect repellent
1	Moleskin, roll (for blisters and calluses)
1	Lip balm
1	Sunscreen
	<b>Miscellaneous</b> (all items at personal expense)
4	Batteries, "C" cell
1	Combination lock
1	Permanent marker (laundry safe)
1	Note cards, 3" x 5", pack
1	Notebook, spiral, blue or black, standard size, college rule
2	Pens, blue or black ink
2	Pencils, #2, mechanical
1	Picture ID
1	Holm Center T-203, Field Training Manual (issued by detachment)

Quotable (**k**):

*"I don't mind being called tough, because in this racket, it's tough guys who lead the survivors."*

-- General Curtis E. Lemay, Chief of Staff, USAF

## **CHAPTER 4: MEDICAL TREATMENT AND FIRST AID (f)**

**1. MEDICAL TREATMENT AND MEDICINE.** It is imperative to arrive at FT in good physical and mental health. You will be required to follow basic rules for any and all prescription and over-the-counter (OTC) medications taken while at FT.

**a. Physical Exams.** In order to attend Field Training you must have a valid military physical exam on file, such as one from DODMERB or MEPS. Further, if there has been a significant change in your health since your physical exam was completed, such as surgery or diagnosis of a chronic disease, you must inform your detachment before proceeding to FT. Failure to do so could result in your immediate removal from FT.

**b. Immunizations.** Cadets are required to provide proof of vaccination, such as a record of immunizations from a doctor. Medical personnel at FT will review the records and determine which of the following immunizations cadets may/will receive within the first days of training: Tetanus/Diphtheria, Hepatitis A/B, Human Papillomavirus (females only), Measles/Mumps/Rubella, Varicella, Pneumococcal/Polysaccharide, Meningococcal, Zoster, and Influenza. Cadets who provide no proof of immunization will be considered as having no previous vaccinations at all and will be administered any and all required vaccinations.

**c. Medications.** During in-processing cadets will also disclose all prescription / non-prescription medications to a physician. Although we recommend that you not bring any medications to FT, you will be allowed to keep items such as aspirin, Tylenol, Midol, over-the-counter antacids, general multi-purpose vitamins, topical medications/creams, non-sudafed Claritin or Zyrtec (Zyrtec-D), and prescription medications. The FTU/CC will determine the disposition and/or management policy for any items that do not fall into the above categories or about which the physical effects are unknown. Weight loss or energy formulas, pseudoephedrine-containing medications, and herbal supplements are not allowed.

**d.** Cadets with prescription medications must have a physician's statement detailing any/all side effects (exception: birth control pills). If any medication hinders completion of FT requirements, the cadet will be released from the FTU without prejudice (Chapter 14, paragraph 2).

(1) Cadets without a doctor's statement will report to the SDCS the morning of TD-2 for medical consultation.

(2) If the medication must be taken the first evening (TD-1), it will be allowed; however, the cadet must report to the SDCS the following morning to request medical consultation.

(3) Secure authorized medications; do not allow use or access by other cadets.

e. Cadets who require regular, scheduled maintenance shots must bring a doctor's note detailing any/all side effects. The note must be presented during in-processing and indicate how often the shots are required and when the next scheduled injection is due. Depending upon the type of medication, the cadet may be responsible for the cost of the injection.

f. Medications received in the mail are not authorized without proper medical coordination.

g. Cadets who receive prescription medication during FT will notify the SDCS and their FLT/CC.

**h. Sick Call.** Every FTU will provide care for any cadet that feels he or she needs to go to sick call for medical or dental reasons. Sick call hours and procedures will be provided to cadets upon arrival at FT. Emergency care for threat to life, limb, or eyesight will be available on a 24/7 basis for emergency situations that may arise.

i. While at FT, all medical treatment will be administered by qualified medical personnel either at the FTU or a medical treatment facility. If you require medical care, notify your FLT/CC. If you require treatment after duty hours, report to the SDCS.

j. Disciplinary action may be taken against any cadet incapacitated for duty due to neglect or misconduct.

**k. CSS will ensure** a line of duty determination (and all associated documentation) is included in the FT package to be returned to the respective detachment, for all cadets treated off base for any medical concerns must ensure. Additionally, cadets must inform medical treatment facility personnel that their release paperwork **must** be signed by a physician. The Department of Labor Office of Workers' Compensation Program will not accept paperwork only endorsed by physician assistants or nurses.

l. Reference paragraph 1.k. above, upon returning from the FTU, cadets should report to the detachment and begin working with detachment personnel to ensure all necessary information has been

submitted to the Department of Labor so that the medical expenses are paid.

**2. HEAT STRESS.** Due to the physical nature of training, heat and heat indexes are always a concern. To combat the effects of heat, you must actively replace the water and electrolytes your body loses through perspiring. *Drink ½ to 1 quart of water per hour for no more than 12 quarts a day or more than 1 ½ quarts an hour for water replacement. Rapid ingestion of large amounts of water (more than 1 ½ quarts per hour) can lead to acute water intoxication.* The preferred method of electrolyte replacement is a balanced diet. Salt food to taste. Sports drinks are acceptable interim measures but should not substitute for meals. Early signs of heat stress disorders include dizziness, headache, dry mouth, unsteady walk, weakness, moist/sweating skin, and muscle cramps. If you feel or note anyone else exhibiting these signs, notify the closest staff member immediately. Take the following actions: remove individual from training; rest individual in shade; take (or give) sips of water. If signs or symptoms do not improve after 30 minutes, transport to nearest medical facility. If signs/symptoms worsen, call an ambulance. Immediate action must be taken if the following (more advanced) signs of heat stress disorder occur: hot body, high temperature, confusion, abnormal behavior, unresponsiveness, coma, vomiting, involuntary bowel movement, convulsions, and weak or rapid pulse. Call an ambulance, take the same actions for early signs, and have the individual lay with feet elevated. If skin is hot to touch, remove as much clothing as possible, pour cool water and fan.

**3. FIRST AID.** While at FT, you will have access to professional medical care if needed. However, there may be situations when emergency medical care is unavailable. In these situations, it may be necessary to administer first aid or “buddy care” until the appropriate medical attention is available. In addition to the heat-related conditions above, the following conditions may arise:

**a. Blisters.** Friction is the specific cause of blisters, the most common FT-related injury. Soft feet, coupled with skin stress and unsuitable shoes and or wet socks, can produce severe blisters. As a result of friction acting on the skin, fluid collects under the skin’s surface at the “hot spot.” Blisters may be clear or watery; if deeper tissues have been affected, they may contain blood.

(1) Protect against abnormal amounts of friction by applying talcum powder or petroleum jelly to the skin before putting on socks. Wearing thick or two pairs of socks during activities can also help

guard against blisters. Keep your feet clean and dry at all times. If your socks get wet, change them as soon as possible.

(2) If prevention fails and a blister forms, clean it, apply a sterile bandage, and leave it alone for 24 hours. If the blister is large, thoroughly clean the area, make a small opening near the edge with a sharp sterile instrument, and drain the fluid with gentle pressure. Once drained, clean the area again and cover with an antibiotic ointment.

(3) Seek appropriate medical attention, if necessary.

**b. Insect Bites.** Although usually not a major health consideration, an insect bite can be extremely painful and in rare cases may cause a severe reaction. Most insect bites may be avoided by using insect repellent, rolling down sleeves and blousing boots in wooded areas. For severe reactions, seek medical attention as soon as possible.

(1) Ants, Bedbugs, Chiggers, and Mosquitoes. Wash the bite area thoroughly with soap and cool water. To control swelling, cover the bite with a very cold wet cloth.

(2) Ticks. Ticks are known to carry various illnesses. Remove imbedded ticks immediately with protected fingertips or tweezers. Scrub the area with soap and water for 5 minutes and search the entire body for additional ticks. If a fever, headache, or chills develop, **seek medical attention.**

(3) Bees, Wasps, and Hornets. Treat the same as above. Also, remove the stinging apparatus.

(4) Scorpions and Spiders. A scorpion or spider bite can cause severe allergic reactions. In the event of a bite, be able to describe the insect. Position the victim's body to ensure the bite is below heart level. Keep victim quiet, warm, and watch for breathing difficulties. Apply a very cold, wet cloth to the affected area and **seek immediate medical attention.**

**c. Plant Poisoning.** Although swallowed plant poisonings are rare at FT, contact poisonings are fairly common. Most contact poisonings result from encounters with Common Poison Ivy, Western Poison Oak, and Poison Sumac.

(1) Symptoms of exposure may not begin for 48 hours after exposure and may include: a severe rash with redness, blisters, swelling, burning, itching, and high fever.

(2) To treat, carefully remove contaminated clothing and wash the exposed area thoroughly with mild soap and water. Apply rubbing alcohol and calamine lotion to control the itching. If a severe reaction occurs, seek medical help.

**d. Animal Bites.** Because much of FT is conducted outdoors, there is always a possibility of an animal bite, though this is rare. If an animal bite occurs, follow these procedures: First, control the bleeding. Flush the wound immediately with cool running water to remove saliva and cleanse thoroughly with mild soap for 5 minutes. Cover the site with a sterile pad or clean cloth and instruct the victim not to move the affected area. **Contact medical personnel or FT staff as soon as possible!**

**e. Snakebites.** All snakebites (poisonous or nonpoisonous) should have immediate medical attention – be sure to get a good identification of the snake (color, designs, head shape, sounds, etc.).

(1) Do not give sedatives, aspirin, or any other medication to relieve pain. Also, do not apply cold compresses, ice, chemical ice packs, or any other methods of cold therapy. Have the victim lie down and keep as still and calm as possible. Adjust the victim's body so that the bite site is below heart level. It is important to be alert for breathing difficulties and be prepared to treat for shock.

(2) Mild to moderate snake bite symptoms include mild swelling or discoloration, mild pain with a tingling sensation at the bite site, rapid pulse, weakness, blurred vision, nausea, vomiting, and shortness of breath.

(3) Severe snakebite symptoms include the following: rapid swelling, numbness, severe pain at the bite site, pinpoint pupils, slurred speech, shock, convulsions, paralysis, unconsciousness, and no breathing or pulse.

(4) Contact medical personnel or FT staff as soon as possible.

**f. Shock.** This generally occurs to some degree after an injury, and when severe, can cause death.

(1) Symptoms of shock may include a dazed or confused look and, depending on the injury, the cadet may be pale or flushed. Breathing will be irregular or weak, vomiting may occur, and the person may lose consciousness.

(2) Have the cadet lie on their back; keep the head level or slightly elevated above the body. Loosen the person's clothing around

the chest and neck. If the skin is pale and cool, cover the person with one or more blankets to provide warmth--be careful not to overheat. If the skin is hot and red, apply towels or napkins soaked in cool water until the skin returns to normal temperature. **Never give a person in severe shock anything to eat or drink!**

Quotable (**k**):

*“In every battle, there comes a time when both sides consider themselves beaten; then he who continues the attack wins.”*  
--General Ulysses S. Grant

## ***CHAPTER 5: FIELD TRAINING ORGANIZATION (k)***

---

**1. OVERVIEW.** FT is organized with FTU staff directing the actions of the in-garrison Cadet Group structure. The Cadet Group structure will be reorganized into a Cadet Wing structure upon deployment to CSJFTC. Information regarding the roles and responsibilities of the Cadet Wing structure at CSJFTC will be provided to you at the appropriate time at FT.

### **2. FIELD TRAINING STAFF**

**a. Commander (CC).** The FTU/CC exercises general command over the staff and cadets assigned to the FTU. The FTU/CC is a colonel and is responsible for accomplishment of the FT mission. The key links between the FTU/CC and cadets are the Director of Operations (FTU/DO), the Commandant of Cadets (FTU/COC), the Flight Commanders (Flt/CCs), and the Cadet Training Assistants (CTA).

**b. Vice Commander (CV).** The FTU/CV is second in command and assumes command in the absence of the FTU/CC.

**c. Director of Support (SD).** The FTU/SD oversees all support staff functions including administration, scheduling, special projects, and host base support.

**d. Scheduling Officer (SDS).** The FTU/SDS is in charge of scheduling and ensures all training curriculum and administration is scheduled.

**e. Project Officer (SDP).** The FTU/SDP coordinates all special projects to include but not limited to: Career Day, FT memorabilia program, guest speaker program, awards ceremony (if applicable), Educator's Visit (if applicable), Det CC Visit (if applicable), Warrior Competition Day and any other public affairs related activities. The secondary role of the FTU/SDP is to replace any FLT/CC having to leave Field Training prior to TD-28. Also, supports COC and ADO where needed to observe standardization and professionalism issues across detachment.

**f. Director of Operations (DO).** The FTU/DO is responsible for the daily operations of the Cadet Group. The FTU/DO supervises the ADO, COC, and FLT/CC functions.

**g. Assistant Director of Operations (ADO).** The FTU/ADO is the primary link between the FTU/DO and the Flt/CCs. The FTU/ADO facilitates information flow to and from Flt/CCs to ensure Flt/CCs have all necessary resources to evaluate cadets and to ensure the group is effectively managing the training program.

**h. Commandant of Cadets (COC).** The FTU/COC maintains discipline, standardizes training, and oversees the physical training (PT), drill and ceremonies (D&C), and standardization programs for the cadet group. The COC supervises Traditional CTAs. The focus of the FTU/COC is standardized cadet training and performance.

**i. Flight Commanders (FLT/CC).** Flt/CCs are the cornerstone of FT. Flt/CCs train, evaluate, counsel, and administrate cadets within the flights. Each flight has its own Flt/CC.

**j. Command Support Staff (SDCS).** The SDCS handles all administrative functions during FT to include but not limited to in- and out-processing, tracking missed training, operating government vehicles in support of all FT needs, manning the command post, updating flag conditions, and managing postal distribution.

**3. CADET TRAINING ASSISTANTS (CTA).** CTAs are POC cadets selected, based on their FT performance and overall cadet record, to return to FT as assistants to active duty staff members. There are two types of CTAs: Traditional and Flight.

**a. Traditional CTAs:** Monitor and assist cadets with specific areas of training. They are not assigned to a specific flight, but coordinate activities for all flights in the group with the COC. The Traditional CTAs consist of the Drill and Ceremonies (D&C), Group, Physical Training (PT), Public Affairs (PA) and Standardization (STANDO) CTAs.

**b. Flight CTAs:** Assist the Flt/CCs with training as directed. In addition to an Flt/CC, each flight will also have a CTA.

**4. CADET ORGANIZATION IN GARRISON AND AT BLUE THUNDER.** While in garrison and at BT, FTUs operate using a cadet group organization (Figure 5-1).

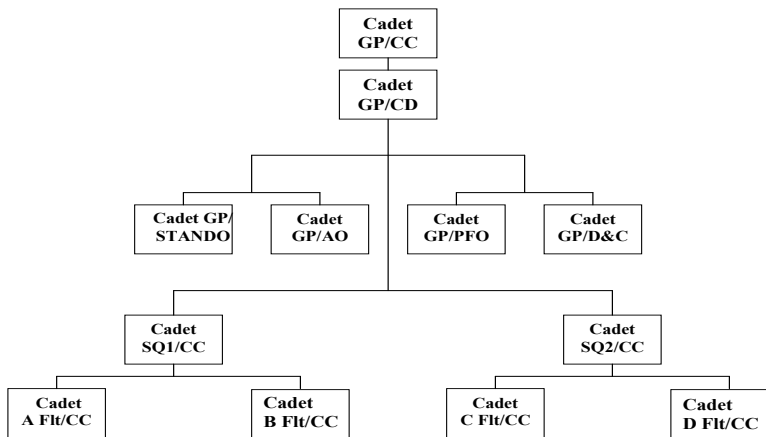

**FIGURE 5-1. Cadet Group Organization in garrison and at BT**

NOTE: There may be up to nine sequentially numbered squadrons in a group. Each squadron will have two alphabetically designated flights.

**5. CADET LEADERSHIP RESPONSIBILITIES.** All cadets are responsible for maintaining discipline and setting a proper example. Cadets in leadership positions can give orders to subordinate cadets. However, they cannot excuse cadets from formations or change orders and regulations. If a cadet in a leadership position is required to be absent from any formation or activity, he/she must notify the next cadet in the chain-of-command to take charge. Cadets may not award merits or discrepancies.

**6. CADET POSITIONS.** As a cadet, you will hold various positions within the cadet organization. The Flt/CCs will assign most of these positions. These positions may be classified as leadership or non-leadership and may be permanent or rotating. Rank will **not** change based on position held. All cadets will wear Cadet 3rd Class rank for the duration of FT. Unless poor performance dictates otherwise, leadership positions will be held for five consecutive days. Prior to each rotation of leadership positions, the incoming and outgoing group commanders will meet with the COC. Also, the outgoing cadet staff will brief the incoming staff on duties and items of interest. All cadet

staff members will be evaluated on their performance. Cadets will hold at least one leadership position during FT.

**7. CADET POSITION DESCRIPTIONS IN GARRISON AND AT BLUE THUNDER.** Table 5-1 lists leadership and non-leadership positions and rotation frequencies while in garrison and while at BT. The FTU/COC may issue additional or more detailed responsibilities for each position.

**a. Cadet Group Commander (Cadet GP/CC).** The Cadet GP/CC reports to the FTU/COC. This individual will coordinate cadet activities and monitor the overall appearance and conduct of the cadet group. The Cadet GP/CC is the delegating authority for the group staff to accomplish work details, inspections, or other special duties and taskings. The Cadet GP/CC must also establish and update the master suspense file.

**b. Cadet Deputy Group Commander (Cadet GP/CD).** The Cadet GP/CD reports to the Cadet GP/CC and assumes command in the absence of the Cadet GP/CC. This individual is responsible for assembling the cadet group for formations and receiving the report from the Cadet SQ/CDs. The Cadet GP/CD will also ensure common areas outside the dorms are clean and orderly.

**c. Cadet Group Drill and Ceremonies Officer (Cadet GP/D&C).** The Cadet GP/D&C reports to the Cadet GP/CC or CD and is responsible for training flights and squadrons on all D&C activities (parade, retreat, reveille, etc) and evaluating their performance during parades. In addition, the Cadet GP/D&C advises the Cadet GP/CC or Cadet CD of the plan for each D&C hour scheduled and serves as the liaison between the Cadet flight D&C officers (Cadet FLT/D&C) and the D&C CTA. The Cadet GP/D&C ensures compliance with AFMAN 36-2203, *Drill and Ceremonies*. The Cadet GP/D&C also ensures parade grounds are marked for parades and reviews.

**d. Cadet Group Physical Fitness Officer (Cadet GP/PFO).** The Cadet GP/PFO reports to the Cadet GP/CC or CD and directs the PT program by coordinating with the PT CTA and Cadet flight physical fitness officers (Cadet FLT/PFO). He or she verifies that all sports rules are standardized in accordance with this guide. The Cadet GP/PFO leads the morning PT and stretching exercises before sports, ensures safety briefings are conducted prior to each activity, and ensures water is available. This individual also relays PT data for warrior flight scoring to the PT CTA.

**e. Cadet Group Standardization Officer (Cadet GP/STANDO).**

The Cadet GP/STANDO reports to the Cadet GP/CC or CD and is responsible for training Cadet FLT/STANDOs on inspection procedures. The Cadet GP/STANDO coordinates with the STANDO CTA and Cadet flight standardization officers (Cadet FLT/STANDO) to standardize the cadet organization. This cadet conducts standardization spot checks on flights and, when possible, accompanies the STANDO CTA on inspections. Cadet GP/STANDOs will continue to perform their duties while at BT and CSJFTC.

**f. Cadet Group Academic Officer (Cadet GP/AO).** The Cadet GP/AO reports to the Cadet GP/CC or CD and is responsible for training Cadet FLT/AO in leading flight academic lessons and group discussion. The Cadet GP/AO must coordinate with the COC to get academic lesson plans on the master training schedule. The Cadet GP/AO reviews each lesson with Cadet FLT/AOs to ensure standardization of information and to consolidate feedback from the flights.

**g. Cadet Squadron Commander (Cadet SQ/CC).** The Cadet SQ/CC reports to the GP/CC and is the liaison between the group staff and the flights in his or her squadron. This cadet is responsible for ensuring standardization of squadron appearance, conduct, and training in accordance with (IAW) Cadet GP/STANDO and Cadet FLT/STANDO guidance.

**h. Cadet Deputy Squadron Commander (Cadet SQ/CD).** The Cadet SQ/CD reports to the Cadet SQ/CC and assumes command in the absence of the Cadet SQ/CC. This individual is also responsible for assembling the squadron for formation and receiving the report from the Cadet FLT/CCs. The Cadet SQ/CD will ensure common areas inside the dorm are clean and orderly.

**i. Cadet Flight Commander (Cadet FLT/CC).** The Cadet FLT/CC plans and coordinates activities within the flight. The Cadet FLT/CC also notifies the Cadet SQ/CC of any problems within the flight and reports flight attendance to the Cadet SQ/CD during formations. The Cadet FLT/CC is responsible for execution of the daily schedule, to include ensuring that his/her flight arrives at all scheduled events on time.

**j. Cadet Deputy Flight Commander (Cadet FLT/CD).** The Cadet FLT/CD assumes command of the flight in the absence of the Cadet FLT/CC. This individual is responsible for assembling the flight during formations, reporting attendance during fire drills/emergency

evacuations, and receiving the report of element leaders. The Cadet FLT/CD also coordinates efforts for FT t-shirts and coins and other items (as applicable with the FTU/SDP). The Cadet FLT/CD serves as a member of the Professional Values Council (PVC) and is responsible for briefing honor lesson plans and facilitating discussions within the flight.

**k. Cadet Flight Academic Officer (Cadet FLT/AO).** The Cadet FLT/AO reports to the Cadet GP/AO and is responsible for briefing academic lesson plans and leading discussions within the flight. The Cadet FLT/AO receives guidance from the Cadet GP/AO on curriculum and discussion topics. The Cadet FLT/AO is also responsible for receiving feedback from the flights and reporting feedback to the Cadet GP/AO.

**l. Cadet Flight Physical Fitness Officer (Cadet FLT/PFO).** The Cadet FLT/PFO manages the flight PT program by coordinating with the Cadet GP/PFO and the PT CTA. The Cadet FLT/PFO relays Cadet GP/PFO rules clarifications, ensures the safety and adequacy of the athletic areas, ensures flight members know the procedures and protocol for warm-up exercises, and administers warm-up exercises in the Cadet GP/PFO's absence. The Cadet FLT/PFO divides the flight into two permanent teams (each having an equivalent number of females and males) and ensures the flight members understand all game rules. The Cadet FLT/PFO also appoints team captains on a rotating basis. After game play, the home team Cadet FLT/PFO turns in the sports report to the PT CTA and returns all sports equipment to its proper storage location.

**m. Cadet Flight Standardization Officer (Cadet FLT/STANDO).** The Cadet FLT/STANDO trains the flight on procedures outlined by the Cadet GP/STANDO, ensures standardization within the flight, and reports discrepancies to the Cadet FLT/CD.

**n. Cadet Flight Drill and Ceremonies Officer (Cadet FLT/D&C).** The Cadet FLT/D&C assists the Cadet GP/D&C with parade practices, parades, reveille, and retreat. The Cadet FLT/D&C also explains drill evaluation procedures to the flight and assists cadets with special drill, remedial drill, and drill competition.

**o. Element Leader.** Element leaders (three per flight) must account for each cadet in the element during duty hours. At formations, the element leader will take roll and report the results to the Cadet FLT/CD. While marching in formation, Element Leaders will call

“**Safety!**” to identify any obstacles in the Flight’s path. Any problems or concerns within the element should be reported to either the Cadet FLT/CD or Cadet FLT/CC.

**p. Guidon Bearer, Color Bearer, and Color Guard.** These cadets coordinate with the Cadet GP/D&C and perform duties as outlined in AFMAN 36-2203. The Color Bearer and Color Guard members must be present for duty at least 10 minutes prior to formations. Individuals will acquire and return equipment for practice/formal parades. Flight guidons must be at all activities unless the FT staff directs otherwise.

**q. Flight Mail Orderly/Alternate.** The Cadet Flight Mail Orderly will acquire all cadet signatures authorizing mail delivery and report to the SDCS section at the designated time to receive mail. All mail must be safeguarded until it is delivered to the addressee or returned to the SDCS section. The mail orderly will collect all outgoing mail and deliver it to the SDCS section at the time designated by FTU/SDS. The Flight Mail Orderly must train the alternate and ensure that individual is available for duty when needed.

**r. Cadet Flight Safety Officer (Cadet FLT/FSO)/Alternate.** The Cadet Flight Safety Officer will ensure the flight is briefed on safety procedures, evacuation plans, and fire reporting procedures. This cadet monitors and ensures flight members are properly evacuated during fires and fire drills. The Flight Safety Officer also ensures that the flight carries road guard equipment to all activities, first aid kits to PT events, and flashlights when traveling during late evening and early morning activities. The Flight Safety Officer must ensure the alternate Safety Officer is knowledgeable of all safety-related procedures and policies.

**s. Cadet Flight Supply Officer.** The Cadet Flight Supply Officer is responsible for three main areas: supply, linen exchange, and facility discrepancy reporting. The Cadet Flight Supply Officer monitors supply storage areas and coordinates with the FTU/SD office for restocking supplies. The Cadet Flight Supply Officer must ensure each cadet has two sheets, one mattress cover/pad, two blankets, one pillow, and one pillowcase. The Cadet Flight Supply Officer is also responsible for organizing and leading a detail to collect and exchange sheets and pillowcases on linen exchange days. Linen exchange will be as directed by the SDCS. In addition, the Cadet Flight Supply Officers will be responsible for reporting and tracking facility discrepancies for

their dorm/bays and will maintain a log of discrepancies that indicates when the discrepancies were reported and their status. Flight Supply Officers report discrepancies to the SDCS using the facility discrepancy form issued at the initial meeting with SDCS. Flight Supply Officers will be the **only** cadets that will deal with the SDCS. When requesting supplies use a supply request form issued at your first meeting with SDCS.

Position	Rotate	Remarks
Cadet Group Commander	5 Days	Leadership
Cadet Deputy Group Commander	5 Days	Leadership
Cadet Group Academic Officer	5 Days	Leadership
Cadet Group Drill & Ceremonies Officer	5 Days	Leadership
Cadet Group Physical Fitness Officer	5 Days	Leadership
Group Standardization Officer	5 Days	Leadership
Cadet Squadron Commander	5 Days	Leadership
Cadet Deputy Squadron Commander	5 Days	Leadership
Cadet Flight Commander	5 Days	Leadership
Cadet Deputy Flight Commander	5 Days	Leadership
Cadet Flight Academic Officer	5 Days	Leadership
Cadet Flight Drill & Ceremonies Officer	5 Days	Leadership
Cadet Flight Physical Fitness Officer	5 Days	Leadership
Cadet Flight Standardization Officer	5 Days	Leadership
Cadet Element Leader (3 per flight)	5 Days	Not Leadership
Guidon Bearer	5 Days	Not Leadership
Color Bearer	5 Days	Not Leadership
Color Guard	5 Days	Not Leadership
Cadet Flight Mail Orderly	No rotate	Not Leadership
Cadet Flight Mail Orderly Alternate	No rotate	Not Leadership
Cadet Flight Safety Officer	No rotate	Not Leadership
Cadet Flight Safety Officer Alternate	No rotate	Not Leadership
Cadet Flight Supply Officer	No rotate	Not Leadership

**TABLE 5-1. Cadet Leadership/Non-Leadership Positions**

Quotable (**k**):

*“Victory smiles upon those who anticipate the changes in the character of war, not upon those who wait to adapt themselves after the changes occur.”*

-- Italian Air Marshall Giulio Douhet

## CHAPTER 6: HONOR CODE AND PROFESSIONAL VALUES (k)

**1. THE CADET HONOR CODE.** *We will not lie, steal, or cheat, nor tolerate among us anyone who does.*" The purpose of the Honor Code is to foster an environment based upon a personal sense of honesty and integrity. Implementation of the Honor Code means you will be trusted to do what is right and must confront those who violate these standards. An honor code violation will result in mandatory counseling with the FTU/CC and possible removal from FT. If you think a violation has occurred or if you have a question about the Honor Code, talk to your Ft/CC.

**a. Lying.** Lying is any statement of untruth, which is meant to deceive or mislead. One example of lying at FT is intentionally signing in at an improper time in order to avoid a regulation violation.

**b. Stealing.** Anyone who wrongfully takes, obtains, or withholds someone else's property without their permission, with the intent to temporarily or permanently deprive another of such property, is guilty of stealing.

**c. Cheating.** In essence, cheating is taking unfair advantage of another. Cheating violates the competitive sense of "fair play." An example of cheating at FT is not completing all required laps during 1.5 mile run portion of the PFA, yet coercing your spotter to indicate otherwise or knowingly allowing it to occur.

**d. Toleration.** Toleration means enduring without complaint. If you know a cadet has lied, stolen, or cheated, and you fail to report or confront the matter, you may be guilty of toleration.

**2. CORE VALUES.** In using the Honor Code, AFROTC is looking to develop officers with character or, more specifically, to produce leaders for the Air Force and build better citizens for America. AFROTC expects to produce officers with the following core values:

**a. Integrity First.** Officers with forthright integrity voluntarily decide the right thing to do and do it in both their professional and private lives. They do not choose the right thing because of a calculation of what is most advantageous to themselves, but because of a consistent and spontaneous inclination to do the right thing. Their inclination to do right is consistently followed by actually doing what they believe they should do and taking responsibility for their choices. In other words, persons of integrity "walk their talk."

**b. Service Before Self.** Officers who are selfless in service to their country, the Air Force, and their subordinates know how to prioritize their loyalties so that their highest loyalty is to the moral principles reflected in the Constitution, then to the profession of arms, then to the mission, and lastly to individuals. People who serve selflessly resist the natural tendency to focus exclusively on self-serving desires and, therefore, do not take advantage of situations for personal pleasure, gain, or safety at the expense of the unit or mission. They share in the danger, hardships, and discomforts of subordinates. Their rank is shown by their commitment to duty and responsibility to others rather than claims of personal privilege or advantage.

**c. Excellence In All We Do.** Officers who are committed to excellence in the performance of their personal and professional responsibilities strive to do their best in everything they are capable of accomplishing. They base their self-esteem and sense of accomplishment not on how their accomplishments compare with others but on how they measure up compared to a realistic appraisal of what they are capable of accomplishing.

Quotable (k):

*“War is an ugly thing, but not the ugliest of things. The decayed and degraded state of moral and patriotic feeling, which thinks that nothing is worth war, is much worse. The person, who has nothing for which he is willing to fight, nothing which is more important than his own personal safety, is a miserable creature and has no chance of being free unless made and kept so by the exertions of better men than himself.”*

-- John Stuart Mill

## ***CHAPTER 7: RULES AND REGULATIONS (k)***

---

---

**1. DISCIPLINE.** By attending FT, you agree to obey the regulations of the Air Force and any lawful orders the FT staff give. An infraction occurs when a cadet, who through design, neglect, or failure to perform duty, violates regulations or commits an act prejudicial to good order and military discipline.

Remember that while in garrison you will be a guest on Maxwell AFB and a responsible user of the Officer Training School (OTS) complex. Certain situations may necessitate cadet interaction with OTS staff and trainees or other military members, so it is paramount to follow all rules and regulations as well as proper military decorum at all times.

**2. PROHIBITIONS.** The following rules apply for the duration of FT. Violations of these rules are severe breaches in discipline and will be dealt with harshly. Mandatory actions will include counseling by the FT staff and or removal from the FTU. **WHILE AT FIELD TRAINING, CADETS ARE RESTRICTED FROM THE FOLLOWING ACTIVITIES:**

- a. Consuming alcohol
- b. Using illegal or unauthorized prescription drugs or substances
- c. Possessing items widely considered as weapons (i.e., any knife, firearm, explosive, etc.)
- d. Using tobacco products (including smokeless)
- e. Possessing igniting devices (matches, lighters, etc.) (see note<sup>1</sup>)
- f. Using a telephone or cellular phone at any time (see note<sup>2</sup>)
- g. Engaging in spirit missions such as procuring food outside the dining hall, leaving rooms during lights out (except for emergencies and latrine use), or engaging in activities not directed by the daily schedule
- h. Going off-base or entering “Off-Limits” areas without prior staff approval (see note<sup>3</sup>)
- i. Operating or riding as a passenger in any motor vehicle or entering the POV parking area
- j. Gambling
- k. Engaging in physically intimate behavior (kissing, intimate touching/hand holding, etc.)

l. Disclosing FT test answers or questions to individuals who have not taken the tests

m. Providing information about GLPs or the LRC to cadets at FT or the detachment

n. Having financial transactions w/permanent-party members

o. Collecting/soliciting money from cadets without prior authorization from the FTU staff

p. Using profanity

q. Wearing civilian clothing (except FTAP students at Academic Preparation when authorized)

r. Wearing or displaying any body piercing / ornamentation or unauthorized tattoos

s. Transiting alone (see note<sup>4</sup>)

t. Visiting another flight area except while on official business

u. Entering the flight storage area without authorization from Flt/CC

v. Having visitors or observers at any time, to include Chapel services, parades, and competitive sports

w. Departing the FTU prior to TD-28 (see note<sup>5</sup>)

x. Consuming candy not provided in MREs

y. Possessing a camera prior to the official awards ceremony. (cadets will store cameras in luggage until authorized to use them)

**Note<sup>1</sup>:** Cadet FLT/CD will collect and turn in any uneaten food following the meal to the respective Flt/CC or CTA.

**Note<sup>2</sup>:** The telephone in the orderly room is for official use only. The SDCS section and SDO will only accept emergency calls.

**Note<sup>3</sup>:** Each base has off-limits areas (i.e., flight line, CATM range, etc.). You are not permitted in these restricted areas **except during training and with an authorized FTU Staff member escort.** Additional off-limits areas include: BX/commissary/shoppette; base housing; permanent party or FT staff living areas; base service station; Class Six; Officer's Club; NCO Club; all dining areas (Burger King, pizza parlor, community center, and snack bars); unused dorms or rooms; exterior fire escape stairs (except in an emergency) and patios; and any additional FTU/CC-designated areas.

**Note<sup>4</sup>:** Cadets must always travel in pairs. If you need to be escorted back from the clinic, for example, contact the SDCS; do not transit alone.

**Note<sup>5</sup>:** Except under emergency circumstances (such as a death in the immediate family -- notification coordinated through the American Red Cross), cadets will not be allowed to depart FT prior to TD-28. Family in the local area, weddings, college/university enrollments, etc. are not emergency circumstances.

**3. TATTOOS.** Cadets are authorized tattoos/brands in accordance with AFI 36-2903, Table 2.5, Notes 1-4. Cadets with inappropriate tattoos anywhere on the body (to include those that are obscene or advocate sexual, racial, ethnic or religious discrimination, or that are prejudicial to good order and discipline and bring discredit upon the Air Force) must be in the process of removing of these tattoos at their own expense before attending Field Training. Further, excessive tattoos, defined as those that exceed 25% of the exposed body part (or are visible above the collarbone) while in any uniform are unauthorized and must be in the process of being removed at the cadet's expense prior to attending FT. Detachment CCs will provide documentation via MFR for any cadet with unauthorized or inappropriate tattoos stating that the cadet has been counseled on AFROTC and Air Force requirements and has begun removal of the aforementioned tattoos.

**4. DRUGS AND ALCOHOL.** The Air Force does not tolerate the use of illegal drugs or chemicals. Failure to divulge drug use will result in disciplinary action and may prevent your entry into the POC. While at FT, the FTU/CC will schedule canine drug sweeps of the dorms. Cadets at FT are strictly prohibited from consuming any alcoholic beverages, regardless of age or situation. Violation of this policy will result in automatic removal.

**5. INFORMATION MANAGEMENT TOOLS (IMT).** The following IMTs are used to document adherence to FT standards.

**a.** AETC IMT 341, *Excellence/Discrepancy Report*. The AETC IMT 341 is used for "on the spot" counseling and documents extraordinary performance in any area of FT. When used for a discrepancy, staff members are specifically documenting a deficiency in military conduct, training, or discipline. All IMT 341s will be turned in to the Flt/CC before CTQ each TD.

(1) Cadets must have three AETC IMT 341s on their person at all times (with first two lines completely filled out).

(2) Multiple discrepancies may be recorded on the AETC IMT 341. The date on the form should reflect the FTU training day such as “TD-3” rather than the Julian/calendar date.

(3) FT staff members issuing discrepancies will personally annotate a cadet’s AETC IMT 341 with a description of the discrepancy (or discrepancies), identify the corresponding category, flight/office information, and signature.

(4) Cadets, who receive multiple discrepancies during FT (especially for the same deficiency), will be counseled by their Flt/CC via the AFROTC IMT 17 and will receive remedial training. Lack of progress will result in a second IMT 17 counseling from the FTU/COC. If the poor performance continues, the cadet will be referred to the FTU/DO who will administer a third IMT 17 counseling, and make a retain/remove recommendation to the FTU/CC.

**b.** AFROTC IMT 84M, *Dormitory Checklist of Authorized Items* (Male)

**c.** AFROTC IMT 84-1M, *Dormitory Checklist of Authorized Items* (Female)

**d.** AFROTC IMT 85, *Squadron Area Inspection Report*; this form is only issued to the SQ/CC and must be turned in to the respective Flt/CC prior to CTQ.

**6. MILITARY DECORUM.** The rules of military decorum are founded on customs and traditions. The responsibility for military decorum is a mutual one in which the junior initiates the act of courtesy and politeness and the senior responds with like courtesy and politeness.

**a. Staff/Cadet Interaction** Use appropriate military courtesies when greeting FTU staff, OTS staff, or any other recognized military members . Always use full rank and last name if you recognize the member or by “**Sir/Ma'am**” as appropriate.

(1) When passing, addressing, or being addressed by staff, the proper greeting of the day is ALWAYS given. The proper greetings of the day are defined by the time of day: “**Good Morning, Sir/Ma'am**”

from 0000 until 1159, **“Good Afternoon, Sir/Ma’am”** from 1200 until 1659 and **“Good Evening, Sir/Ma’am”** from 1700 until 2359.

(2) Cadets will IMMEDIATELY come to their feet and stand at the position of attention when addressed by or addressing any staff member, except during flight room instruction and while eating.

(3) When any staff member or commissioned officer addresses a cadet, the cadet will respond first with the word **“Sir”** or **“Ma’am”** followed by the answer to the question. The only exceptions to this rule are when a yes/no question is asked or when the question “will that be all?” is asked. In those cases, replies will simply be **“Yes/No Sir/Ma’am.”**, or **“Will that be all, Sir/Ma’am?”** Any cadet being addressed will always end all conversations by asking, **“Will that be all, Sir/Ma’am?”** and give the proper greeting of the day. If outdoors, the cadet being addressed will end the conversation by saying, **“Will that be all, Sir/Ma’am?”** followed by a salute and the proper greeting of the day. Other cadets present, but not being addressed will simply render a salute and the greeting of the day (unless in flight formation for which the Cadet Flt/CC will extend all courtesies).

(4) When approaching a group of individuals, the greeting of the day will be rendered to the highest ranking individual(s) first. If the individuals are of the same rank, greet the female(s) first (e.g. A female Captain walking with a male Captain will be greeted with **“Good morning Ma’am, Good morning Sir”**). If all individuals are of the same gender, greet them as a group with “Ladies” or “Gentlemen” (e.g. A male Major walking with a male Captain will be greeted with **“Good morning, Gentlemen”**). If rank is indeterminable, greet the female(s) first (e.g. A group of four males and two females in PT gear will be greeted with **“Good Morning Ladies, Good Morning Gentlemen”**).

**b. Reporting** Reporting procedures will be accomplished for both commissioned and enlisted staff members and CTAs.

(1) For a single cadet ordered into an office, reporting procedures are as follows:

(a) Center on the door or cubicle entrance and knock once (loud enough to be heard in an average size room). Do not knock on the door or cubicle wall if a conversation is taking place in the office.

(b) When given the order, enter, close the door (if you opened it), march using the most direct route to the staff member,

perform the appropriate facing movement, (if on carpet, turn in a crisp, military manner), center yourself two paces away from the individual, salute if reporting to an officer and CTA and state: **“Sir/Ma’am, Cadet (last name) reports as ordered.”**

(c) When reporting to an officer or CTA , the reporting cadet will hold the salute until the officer or CTA drops their salute and remain at the position of attention until told otherwise.

(d) At the end of a conversation, cadets will stand and assume the position of attention (if at a different position) and ask, **“Will that be all sir/ma’am?”** If so, take one step backwards, salute (if reporting to officers or CTAs) and render the proper greeting of the day, perform the appropriate facing movement to leave, and take the most direct route out of the office or cubicle. (If on carpet, turn in a crisp, military manner.)

(2) When multiple cadets are ordered into an office, reporting procedures are as follows:

(a) A selected cadet will center on the door or cubicle entrance and knock once (loud enough to be heard in an average size room). Do not knock on the door or cubicle wall if a conversation is taking place in the office.

(b) When given the order, enter, close the door (if you opened it or are directed to do so), march using the most direct route to the staff member, perform the appropriate facing movement, (if on carpet, turn in a crisp, military manner), all cadets will center two paces away from the individual with a selected cadet standing on the right, and salute (if officer or CTA). This cadet will state on behalf of the others, **“Sir/Ma’am, Cadets (give last names of the whole party) report as ordered.”**

(c) All cadets will hold the salute (if officer or CTA) until the officer drops their salute and remain at the position of attention until told otherwise.

(d) At the end of the conversation, all will stand and assume the position of attention (if at a different position) and the selected cadet will ask, **“Will that be all sir/ma’am?”** If so, all cadets will take one step backwards, salute (if reporting to officers or CTAs)

and the selected cadet will render the proper greeting of the day. All cadets will perform the appropriate facing movement to leave, and take the most direct route out of the office or cubicle. (If on carpet, turn in a crisp, military manner.)

(3) If a cadet is not ordered to report, but needs to see a staff member in their cubicle or office to make a statement or ask a question, the cadet will use the preceding procedures with the following exception: instead of using the above reporting statement, use the appropriate remarks: **"Sir/Ma'am, Cadet (last name) reports."** Once acknowledged by the staff member, the cadet will continue with the question or statement.

### c. Respect towards FT cadre

(1) Use one of the following *seven basic responses* appropriate to begin speaking to, respond to a direct question from, or as instructed by a staff member:

(a) **"Yes, Sir (Ma'am)."**

(b) **"No, Sir (Ma'am)."**

(c) **"No excuse, Sir (Ma'am)."**

(d) **"Sir (Ma'am), I do not know."**

(e) **"Sir (Ma'am), I do not understand."**

(f) **"Sir (Ma'am), may I make a statement?"** (not necessary when responding to a direct question)

(g) **"Sir (Ma'am), may I ask a question?"**

(2) If you need to excuse yourself to pass by or through an individual or group of individuals, politely state, **"Sir (Ma'am), Pardon me please."**

### d. Saluting

(1) The salute is one of the oldest military traditions. It is a courtesy exchanged between members of the armed forces as both a greeting and a symbol of mutual respect. The uniform hat is worn and salutes are rendered in all outdoor areas, unless specifically indicated otherwise. Although inappropriate at certain times, it is never incorrect to salute a senior officer outdoors as a courtesy and a greeting. Do not salute indoors unless formally reporting in to a staff member's office or

upon receiving an award at an awards ceremony. Do not salute when reporting to enlisted staff members.

(2) In detail formations (two to four cadets), all will extend military courtesies as appropriate. In normal formations (5 or more cadets), the cadet in charge renders the military courtesies for the formation.

(3) Cadets will initiate the salute in time to allow the officer/CTA to return it, but not from such a distance as to hinder communication. To prescribe an exact distance for all circumstances is not practical, but good judgment indicates when salutes will be exchanged. (**NOTE:** A standard rule of thumb is to use the same distance prescribed for rendering a salute to the Colors—approximately six paces.) At no time will a cadet turn their upper body to salute someone behind them nor will they salute someone they approached from the rear. If marching, they will continue as needed. If stationary, they will use appropriate facing movements

(4) Cadets passing an officer engaged in conversation will render a salute but not interrupt with the greeting of the day. If the officer does not return the salute, the cadet will continue and then drop the salute once abreast of the officer.

(5) If at double-time, execute quick-time, render a salute and verbal greeting and then resume double-time once your salute is returned. All cadets not in formation will salute and greet officers and CTAs. If in formation and at double-time, the formation commander may simply render a verbal greeting rather than bring the formation to quick-time to salute.

(6) If called to receive an award, proceed in a crisp, military manner and stand approximately one arm's length in front of the presenter. Extend the right hand and shake the presenter's hand while taking the award with the left hand. Then render a salute if the presenter is a commissioned officer. Exit the area in a crisp, military manner. If there are multiple award presenters, side step down the line repeating the same procedure of shake, take, and salute, unless the ceremony is indoors. If indoors, only salute the presenter of the award, but shake the hands of everyone else on the line.

(7) FTU staff and cadets will render proper customs and courtesies even if participating in scheduled training or athletic events.

The only exceptions to this are if cadets and staff are actively participating in the LRC/Project X, Physical Fitness Assessment (PFA), or other events with cadets actively “encumbered” and staff actively engaged in safety-spotting or evaluating performance. In these situations, safety and common sense should always prevail. Personnel outdoors in uniform face the flag (if visible) or the music and assume the position of Parade Rest upon hearing the first note of “Reveille” or “Retreat”. If the flag is being raised during "Reveille", face the flag and render a salute. Upon hearing the first note of “The National Anthem” or “To the Colors”, come to attention, face the flag (if visible) or the music and salute. Hold your salute until the last note of the music is played. When indoors, do not salute, stand at attention and face the flag. When in civilian clothes or PT uniform indoors or outdoors, come to attention and place your right hand over your heart.

(8) Salute all occupied staff cars with front license plates indicating senior officers and occupied USAF staff cars (vehicles with white tops).

(9) No-salute areas. Saluting is not required in the following locations: assault/confidence course, Air and Space Expeditionary Force (AEF) exercise/Blue Thunder site, Baseline Expeditionary Leadership Problems (BELPS) site, Leadership Reaction Course (LRC)/Project X, OTS track, the flickerball operation fields (competitive sports fields), and the covered area between 1487 and the COT Addition. The drill pad, parade field, and PT areas are no-salute areas during instruction only. Cadets will salute superiors when reporting in and out during these activities. Upon completion of instruction all cadets will resume rendering salutes in these areas.

(10) When encountering FTU staff, OTS staff, COT trainees, or other military members wearing the staff or AF physical fitness uniform, cadets are not required to salute, but will render a verbal greeting.

#### **e. Academic Building protocol**

(1) Hallway Guidance. Cadets will walk (not march or run) in a military manner, with a sense of purpose, and with hands cupped, single file, on the right side of the hallway. It's not necessary to halt at every doorway or intersection, but they will watch for people coming out of offices/around corners. In order to prevent undue carpet wear, cadets will not square corners in carpeted areas. Cadets may not speak unless making on-the-spot corrections to other cadets, addressing or being

addressed by FTU or OTS staff or visitors, or giving the greeting of the day.

(2) Restroom Guidance. Cadets will enter, use the facilities and then exit in an expedient manner. Cadets may not speak unless making on-the-spot corrections to other cadets or addressing or being addressed by FTU or OTS staff or visitors. Cadets will not give greetings to staff or other cadets or trainees while in the restroom.

(3) Auditorium (mass lecture) procedures. Cadets will sit according to assigned seating arrangement. After taking their seat, they will maintain good order, discipline and posture. During the lecture, cadets may not talk, sleep or move unnecessarily (i.e., stretching, gathering notes before dismissal, etc.), and will not engage in any activity not directly related to the current lesson.

(a) Auditorium Opening Guidance. The Cadet GP/CC will stand and command, **“CLASS, PREPARE FOR INSTRUCTION.”** At this time, cadets will stand at parade rest in front of their seats. Then the Cadet GP/CC commands, **“CLASS, ATTENTION.”** Cadets will then move to the position of attention. The Cadet GP/CC will then turn to the lecturer, salute (for officers only) and report, **“SIR/MA’AM, MAXWELL \_\_\_ IS READY FOR INSTRUCTION.”** The instructor will return the salute, if applicable, and direct the class to take their seats, and the lesson will begin.

(b) Asking/Answering Questions. When cadets wish to ask a question or provide an answer during a class auditorium lecture, they will remain seated and raise a hand. When the lecturer recognizes a cadet, the cadet will stand up, state their name and flight and ask the question/give the answer, unless directed to do otherwise by the lecturer. Proper military customs and courtesies, including **“SIR/MA’AM”** will be used.

(c) Auditorium Closing Guidance. Once the instructor/lecturer indicates they are ready to close class, the Cadet GP/CC will stand and command, **“CLASS, PREPARE FOR DISMISSAL.”** At this time, cadets will set aside class materials and be ready to stand. Next, the Cadet GP/CC will issue the command, **“CLASS, ATTENTION”**, upon which cadets will move to the position of attention. The Cadet GP/CC will then turn to the lecturer, salute (for officers only) and report, **“SIR/MA’AM, MAXWELL \_\_\_ IS**

**READY FOR DISMISSAL.”** When the instructor/lecturer departs the auditorium, they will command **“CARRY ON.”** The class will loudly echo, **“CARRY ON, SIR/MA’AM.”** If the command is not given, the Cadet GP/CC will command **“CARRY ON”** once the instructor has left the auditorium.

(4) Flight Room procedures. When class is not in session, cadets will call the room to attention, in unison, when a commissioned officer or CTA enters or exits the room, provided there is not already a commissioned officer of equal or greater rank in the room. As the officer breaks the plane of the door, all cadets will command, **“ROOM, ATTENTION.”** When exiting, if the officer or CTA commands **“CARRY ON,”** all cadets will echo, **“CARRY ON SIR/MA’AM.”** If the **“CARRY ON”** command is not issued, cadets will resume normal duties when the officer has left the room. When class is open, the flight room will not be called to attention for visitors regardless of rank. This is an academic session and will continue uninterrupted. When class is stopped for a break and the same lesson will resume upon conclusion of the break, cadets will not call the room to attention when the instructor enters or exits the room.

#### **f. Dormitory Protocol**

(1) Hallway Guidance. If any FTU or OTS staff or CTA is about to pass you in the hallway, halt (if moving), come to attention, place your heels to the wall, allow them to pass, and render the greeting of the day and then carry on. If wearing a Camelbak, come to attention as near to the wall as possible without hurting yourself or damaging the wall or Camelbak. When passing any FTU or OTS staff or CTA, cadets will brace the wall and state **“Sir/Ma’am, Cadet (last name) requests permission to pass.”** Once given permission, the cadet will move quickly in their intended direction and give the appropriate greeting of the day. When in stairwells, render the proper greeting but do not stop moving.

(2) Foyer/Day Areas/CQ Office/Hallways. Cadets will not call foyers, day areas (open area used as a dayroom), the CQ Office, or hallways to attention when senior personnel enter, but will show proper respect for all FTU and OTS staff and other commissioned officers when present in the dormitory. If seated, cadets will stand and render the proper greeting of the day, or, if already standing, will simply render the proper greeting of the day. **EXCEPTION:** If there are two

or more cadets in the foyer, dayroom, day-area, or hallway and the FTU/CC, or an O-6 or above enters the building/area, the cadets will call the building/area to attention unless there is an officer of equal or higher rank already in that specific building/area. If there is only one cadet, the cadet will stand at the position of attention and render the proper greeting of the day.

(3) Entering/leaving Dormitory Rooms. When FTU and OTS staff and other commissioned officers enter or leave a room, the first person to take notice will call the room to attention, provided there is not already a commissioned officer of equal or greater rank in the room. If a cadet is alone in the room, that cadet will come to attention as the officer enters or leaves, but not call the room to attention.

**g. Bus Protocol.** Cadets will fill busses from back to front with two cadets (unless otherwise directed) in each seat. Sit at the position of attention and read the selected portions of this manual or the Airman's Manual as directed. You may rest your hands on the seat in front of you for safety.

## **7. DISCRIMINATION AND SEXUAL HARASSMENT**

**a.** The Air Force has a zero tolerance policy towards discrimination and sexual harassment.

(1) Discrimination is defined as any action that unlawfully or unjustly results in unequal treatment of persons or groups based on race, color, gender, national origin, religion, age, and, if civilian, handicapping conditions, for which distinctions are not supported by legal or rational considerations.

(2) Sexual harassment is a form of gender discrimination that involves unwelcome sexual advances, requests for sexual favors, and other verbal or physical conduct of a sexual nature (see Attachment 2).

**b.** If at any time during FT you feel you are a victim of discrimination or sexual harassment (whether committed by a staff member, CTA, fellow cadet, or host base personnel), notify any FT staff member immediately.

**8. PROPERTY SECURITY.** Security of personal valuables and government property is paramount. To help secure the premises, you must notify the FT staff of any unauthorized persons in the area.

**a. Personal Valuables.** Do not bring high value items to FT. It is your responsibility to secure personal items, and you must keep such items locked in your security drawer, or duffle bag while in the field, at all times. Report thefts or losses to your Flt/CC immediately.

**b. Security violations:** Security violations at FT indicate one's inability to safeguard classified information and other government property while on active duty. The following personal items, if found unsecured, constitute a security violation: 1) Any photo ID; 2) Military Orders; 3) US currency greater than or equal to \$1. Additionally, any security drawer found unsecured (regardless of contents) will constitute a security violation. If you are found guilty of an infraction, you will be counseled via the AFROTC IMT 17 by the Flt/CC; a second violation will result in an AFROTC IMT 17 counseling from the COC; a third violation will result in an AFROTC IMT 17 counseling from the FTU/DO, who will evaluate the cadet's ability to remain at Field Training. Other personal items found unsecured **DO NOT** constitute security violations, but will be confiscated by the Flt/CC until the end of Field Training.

**9. GOVERNMENT PROPERTY.** You will be accountable for all property (including uniforms) assigned to you until the items are returned or another individual signs for them. You must maintain all property in good condition. Do not deface, tear, or disassemble; do not move equipment without permission; report all malfunctions or damage.

Quotable (k):

*"Integrity is the fundamental premise for military service in a free society. Without integrity, the moral pillars of our military strength, public trust, and self-respect are lost."*

-- General Charles A. Gabriel, Chief of Staff, USAF

## **CHAPTER 8: GENERAL ACTIVITIES IN GARRISON (k)**

---

**1. DAILY SCHEDULE.** A typical daily schedule while in garrison could resemble the following. Note: AFROTC cadets and staff will defer to the host base for *Reveille* and *Retreat* while in garrison.

0400 Wakeup; UNIFORM: PTU  
0405 Transit Time (TT) to Track  
0410 PT  
0520 TT to DFAC  
0530 Breakfast UNIFORM: BDUs/ABUs or PTU  
0630 TT to Dormitories  
0645 Personal Hygiene /Dorm Maintenance (PH/DM)  
0730 TT to Parade Field; UNIFORM: BDUs/ABUs  
0745 Parade Practice  
0900 Pass In Review Parade  
1015 TT to Dining Hall  
1030 Lunch  
1130 TT to Dormitories  
1145 Open Ranks Inspection (ORI) / Stand By Inspection (SBI)  
1330 PH/DM  
1345 Group Leadership Problem (GLP) w/ Flt/CC  
1500 Flt/CC Lesson: Teambuilding  
1620 TT to Dining Hall  
1630 Dinner  
1730 TT to Dormitories  
1745 PH/DM; UNIFORM CHANGE: PTU  
1800 COC Determined Physical Training (PT) Activity  
1930 Flt/CC Time (Flt/CCT)  
2000 Individual Cadet Time, as applicable  
2030 Call To Quarters (CTQ)  
2100 TAPS/Lights-Out

**2. CALL-TO-QUARTERS (CTQ).** CTQ is free from constructive training. Staff members may walk through the area but will not initiate meetings with cadets. During CTQ, you must remain in the flight area unless performing official duties related to your assigned position (cadets must sign in/out of flight area). Additionally, cadets may perform details, write letters, conduct meetings, or prepare uniforms. Sleeping / lying in bed is not authorized. This is your time. Meetings concerning additional duties or special projects will not be held during CTQ if they require staff member involvement. Immediately prior to lights out, TAPS will sound. You must be in bed with lights out by the time TAPS is finished.

**3. LIGHTS OUT.** Between *Taps* and *Reveille*, you are not authorized to engage in any activities other than sleeping (i.e., writing letters, reading, talking, etc.) You will not leave your bed except in the event of an emergency or to use the latrine. Talking in the latrine is prohibited after lights out. The Staff Duty Officer (SDO) may conduct bed checks to ensure complete accountability. Lights out violations will result in AFROTC IMT 17 counselings.

**4. SIGNING OUT/IN.** You must sign an AFROTC IMT 82, *Student Sign Out/In Register*, anytime you will miss activities on the schedule, or when proceeding anywhere without your flight. Always consult your Flt/CC or CTA and sign out prior to proceeding to any medical treatment. Ensure times are accurate to the minute. If there is a line of cadets waiting to sign out or in (to attend religious services for example), enter the time you joined the line. It is your responsibility to return to quarters prior to CTQ. If you cannot return on time, contact the SDO.

## **5. FORMATIONS**

### **a. Definitions**

(1) Detail - Formation of two to four cadets, including the cadet in charge. In formations with three or four cadets, the formation is properly sized and the cadet in the right rear position will lead the formation. When in details of two the detail leader marches on the right. When in a detail to retrieve a guidon, the cadet on the right will carry it, regardless of their assigned duty for that day.

(2) Flight - Formation of five or more cadets. This includes a designated flight leader, usually the Cadet Flt/CC. There will be at least two but no more than four elements. While on the OTS Complex, OTS flights will normally march with two elements and AFROTC flights will normally march with three elements.

(3) Guide - The guide marches in front of the highest numbered element leader and will regulate the direction and rate of marching (front-right corner when in column formation).

(4) Road Guard - Cadet designated to stop traffic when cadets cross a road or parking lot.

## **b. General Guidance**

(1) The Cadet FLT/CC's first responsibility is the safety of the formation. Therefore, situational awareness of the surroundings is critical and must be maintained at all times, even when stationary.

(2) Cadets will not talk while in formation.

(3) Double Time. Cadets will double-time when wearing the PTU, except within one hour after a meal. After the first PFA, cadets may also double-time when wearing BDUs/ABUs (at the discretion of the Flt/CC or CTA). Cadets may double time on paved surfaces to and from physical conditioning activities except when crossing the street. Cadets will not double time during hours of darkness for safety reasons (EXCEPTION: Approved formation runs may take place during dawn and dusk, and if the formation is carrying flashlights or reflective gear).

(4) All cadets will move on sidewalks, parking lots, troop walks, and other improved surfaces. When there are none available, use unimproved surfaces with caution and while marching at ease. The Cadet FLT/CC will act as road guard for flights with 10 or fewer cadets. If traveling along a roadway, march with as few elements as practical (usually two) and in the designated running lane. If no designated running lane exists, cadets will march against the flow of traffic.

(5) All members of a formation must carry operable flashlights during hours of darkness and period of reduced visibility. (EXCEPTION: Reflective gear is a suitable substitute during formation runs.)

(6) Cadets do not have the authority to place flights *“at ease”* or *“at rest”* at any time. If a flight member wishes to address the flight, he/she must first request permission from the Cadet FLT/CC to address the flight and then do so from the position of attention. The flight will also be at the position of attention. Individual flight members cannot address the flight while the flight is in transit. However, flight members

may request from the Cadet FLT/CC permission to ask a question or to make a statement in order to address a safety concern.

## **6. ROAD GUARD PROCEDURES.**

### **a. General Information.**

(1) Required safety equipment (only when pulling road guard as a detail): fluorescent/reflective vest (worn by road guards during hours of darkness) and flashlight (during hours of darkness).

(2) Cadets will not “piggyback” units (march more than one unit across the street without allowing traffic to proceed between them) when crossing streets unless directed to do so by FTU staff.

(3) The Cadet Flt/CC will render all courtesies for the flight. If an officer (on foot) or staff vehicle passes (from the front) the person in charge will render courtesies. If a staff vehicle approaches the flight while crossing an intersection the road guard will not salute (due to safety). The person in charge will march the flight across the street, halt the flight, call in the road guards, and then render courtesies to the staff vehicle.

### **b. Procedures.**

(1) For safety reasons, flights will always be halted prior to entering a hazard area so the Cadet Flt/CC can ensure the safety of the posting road guards. The Cadet Flt/CC will ask permission of the FTU staff member escorting them to cross road or enter the hazard area.

(2) The Cadet Flt/CC will move forward, post in front of the flight at the sidewalk/hazard edge.

(3) The Cadet Flt/CC will wave traffic past OR motion for the traffic to stop by extending either arm and displaying the palm of the hand with the fingers pointed upward.

(4) The Cadet Flt/CC will then march into the intersection and post in the middle of the road, perform an about face (so they’re facing the flight), ensure traffic is stopped and command, **"ROAD GUARDS OUT."**

(5) On the command, "**ROAD GUARDS OUT,**" the left road guard will go to the closest lane, and the right road guard will go to the farthest lane, face oncoming traffic at parade rest with the right arm up, palm flat with the fingers pointed upward. If carrying a flashlight, road guards will hold the flashlight in the extended arm with the beam pointed down.

(6) The Cadet Flt/CC will command the flight to march across the intersection and perform the necessary facing movements so they can observe the flight at all times.

(7) Once the flight is through the intersection, the Cadet Flt/CC will halt the flight and command, "**ROAD GUARDS IN.**"

(8) The Cadet Flt/CC will remain in the intersection and continue to halt existing traffic while the road guards return to the rear of the flight.

(9) The Cadet Flt/CC does not give further commands (e.g., "**FORWARD MARCH**") until rejoining the flight.

## **7. GUIDON PROCEDURES**

**a.** Each flight of six or more cadets will carry their guidon from start to end of academic day while marching from one location to another on Maxwell AFB, except when specifically instructed by staff to do otherwise, or due to weather advisories.

**b.** The guidon will be carried to all events except the BT exercises, BELPS, LRC/Project X, PT, or other events as directed by FTU staff. If there is no guidon holder at the event, the guidon bearer will make every effort to ensure the guidon is stored/displayed properly and will not become a safety hazard. Guidons will not be posted by jamming them into the ground.

**c.** Guidon Bearer. The flight guide will carry the guidon with the right hand. The guide will position the ferrule of the staff six inches from the ground when the flight is marching and resting on the ground when the flight is halted. Until the flight's pennant is awarded, flights will carry the guidon without the pennant. When the guidon is carried by a detail or a formation too small to be a flight, the guidon is carried by the individual on the front right.

d. Storage of the Guidon. Flight guides are responsible for storing the guidon in the appropriate rack when not in use. Guidons shall not be placed with the tip of the ornament on the ground or with the pennant wrapped tightly around the staff. During parade practice, the guidon is placed by the first set of bleachers. If entering a building that does not have a storage rack, cadets will take the guidon inside with them and place it out of the way, leaning into a corner so that it will not fall. (NOTE: When entering a building with a guidon, cadets will announce "**GUIDON**" in order to alert others in the area to the hazard.)

e. Cadets will take care of the guidon. If any part of the guidon breaks, cadets will not attempt to repair it. They will take the guidon to their Flt/CC or CTA for repair.

## **8. BUILDING ENTRANCE AND DEPARTURE PROCEDURES.**

Entrance and departure procedures are necessary in order to promote good order and discipline among cadets while entering or exiting any permanent structure, including Academic buildings, Dormitories, or the Dining Facility (after clearance from the Mess Checker). These procedures apply to squadron, flight and detail formations. If a door becomes propped in the open position, the last cadet entering will close it.

a. Upon halting a flight near an entrance in which entry is required, the Cadet Flt/CC will command, "**COLUMN OF FILES FROM THE RIGHT (LEFT).**" On the informational command, the guide will take the position in front of the selected element. Once the guide is in position and at order guidon, the Cadet Flt/CC will command, "**FORWARD.**" Upon the Cadet Flt/CC's command of "**FORWARD,**" the element leader of the selected element turns his/her head 45 degrees to the right (left) and echoes the Flt/CC's command of "**FORWARD**". The guide will go to the carry position (if carrying a guidon) as the element leader echoes the command. At the same time the remaining element leader(s) turns his/her head 45 degrees to the right (left) and commands, "**STAND FAST.**" Their heads stay turned until they step off. After all element leaders have echoed the appropriate command, the Cadet Flt/CC will command, "**MARCH.**"

b. Upon the Cadet Flt/CC's command of "**MARCH**" the guide and all remaining members of the element will step off. Once the guide has

reached the door, he/she will hold it until the last flight/element member has entered. The element leader of the selected element will step off toward the appropriate entrance. The element leader of each remaining element will command, **"FORWARD, MARCH"** as the last cadet in each preceding element has passed. Giving the command as the left foot strikes the ground will ensure their element is in step with the preceding element. All elements will incline in the appropriate direction, following the leading element in successive order.

c. If carrying a guidon, the guide will place the guidon in the guidon stand (if available). The Cadet Flt/CC will be the last person from his/her flight to enter the building.

d. While marching as a detail, the cadet in charge will command, **"DETAIL HALT,"** followed by the command of **"FALL OUT."** The cadets will then enter the building.

e. The Cadet Flt/CC will be the first member of the flight to depart the building and will designate the position for forming the flight. The flight will exit the building and form up on the guide, in line formation, three elements, facing the Cadet Flt/CC. When departing as a detail, cadets will exit the building in an orderly manner and form up on the sidewalk. There will be no talking in formation. Cadet Flt/CCs will take care to not block traffic into or out of the building. The last cadet in a formation will ensure building doors close behind them.

**9. RELIGIOUS ACCOMMODATIONS.** The Air Force values the free exercise of religious beliefs and seeks to accommodate their practices within the limits of military requirements. Your FT host base has a chaplain on call 24-hours a day and offers Protestant, Catholic, and other religious services. A representative from the Chaplain's Office will cover these services in-depth during the Chaplain Program briefing. Only on-base religious services are authorized. Some faith groups may require religious observances that fall within a standard training week; and not on the weekend as understood by the Gregorian Calendar. Cadets must understand that accommodation will be sought to the best of the ability of the AFROTC's Command. However, accommodation begins with a cadet's understanding that the military mission and training requirements may cause conflict with standard worship practices, and that full accommodation may not be possible. Cadets may feel free to discuss the issue of accommodation in detail with the OTS Chaplain. You will receive separate guidance regarding religious accommodations at CSJFTC after arriving at FT.

**10. INDIVIDUAL CADET TIME (ICT).** ICT will take place in conjunction with scheduled religious activities. If you do not attend religious services, you will have ICT. During this time, you must remain in the flight area and may perform details, write letters, conduct meetings, or prepare uniforms. You will not lie down or sleep and your Flt/CC and/or CTA may initiate meetings, counseling, or training.

**11. TELEPHONES.** You are not authorized to use a telephone at any time during FT. If you bring a cellular phone (Palm Pilot, Blackberry, or other communication device), you must turn it in to your Flt/CC upon reporting in to FT; the items will be returned on TD-28.

## **12. MAIL**

**a.** While in-garrison, the Flight Mail Orderly (or alternate) will pick up incoming flight mail from and deposit outgoing mail into the designated mailbox in the SDCS office during the designated hours, Monday through Saturday (except holidays). Separate instructions will be provided for mail pick-up at BT and CSJFTC.

(1) Mail Orderlies will report in to the SDCS office as follows: **“(Alpha/Bravo/etc.) Flight Mail Orderly reports to pick up the mail.”** The SDCS member will grant permission. After retrieving the mail, cadet will report out by saying, **“Will that be all, Sir/Ma’am?”**

**b.** Ask your parents, spouse and friends not to send “care packages” to you during any portion of FT or mail to you during the last 5 days of training. Cadets are not allowed to retain food items due to health concerns (spoilage) or environmental concerns (potential to attract rodents or insects). Other items such as magazines must be placed in the storage area unless approved by the Flt/CC.

(1) Foods. You may return the package to sender. If so, you will prepare the package for mailing and pay all costs. You may also dispose of the food items or give them to your Flt/CC to dispose of. If food items are non-perishable and the cadet does not wish to pay postage costs to return them, the Flt/CC will retain the food until the end of FT. The AF will assume no liability for lost or stolen items.

**c.** Your mailing address during FT follows:

**Cadet (Last Name, First Name MI)**

**MAXWELL \_\_\_ (1, 2, etc.)**

**501 Lemay Place N.**

**Maxwell AFB, AL 36112**

## **CHAPTER 9: DINING FACILITY PROCEDURES IN GARRISON (k)**

---

**1. GENERAL INFORMATION.** The in-garrison OTS Dining Facility (DFAC) serves a nutritious, balanced diet designed for active cadets. Cadets are encouraged to eat three square meals daily. Cadets who choose not to eat are still required to process through the DFAC with the flight. Look at the menu before entering the serving line and process through the line quickly. Use courtesy and etiquette when requesting items from the personnel at the serving line. You will consume everything you take, so be reasonable when requesting food! **Food will not be taken from the DFAC.**

The OTS DFAC also services OTS staff and trainees, so be sure to move purposefully and quickly through the facility. Remember proper customs and courtesies at all times.

a. During each meal period selected cadets will be designated as water monitors. Upon arriving at the DFAC, these cadets will request permission to be excused for water monitor duty, leave their flight, and proceed to the kitchen to begin filling glasses of water for the cadets in the serving line. Once the current water monitor is relieved of duty by the in-coming water monitor, he or she will immediately process through the serving line as quickly as possible.

b. When Meals Ready to Eat (MREs) or box meals are offered in lieu of the standard meal, all items in the MRE or box lunch are authorized for consumption. No items may be kept after meal period.

### **2. ENTRANCE PROCEDURES**

a. Mess checkers will pick up the dining priority list and MREs prior to the first flight's arrival time at the DFAC and will work as a team until the last flight (regardless of program) has met their dining priority. The on-duty mess checkers have the authority to clear flights into the DFAC early/late if there are no other flights waiting and the early/late flight will not inhibit any other flight's on-time entry into the facility.

b. All flights will use the following procedures to access the OTS DFAC:

1) Flights will arrive no more than 3 minutes before or after their scheduled dining priorities. The Cadet Flt/CC will note the time they initially halt the flight in front of the dining hall as their official arrival time. For example, if a flight has to wait for another flight to clear the bay area, they will still annotate their initial halting time as their official arrival time. Cadet Flt/CC are responsible for coordinating with other Cadet Flt/CCs awaiting entry to ensure they do not skip or make another flight late by arriving out of their 6-minute arrival window.

2) The Cadet Flt/CC will halt the flight, place them at "Parade Rest", and then take the most direct and unobstructed route to within one pace in front of the mess checker, halt, initiate a salute and say, "**SIR/MA'AM, \_\_\_ Flight reports with a dining priority of \_\_, we arrived at \_\_.**" If the flight arrives on time, the mess checker will say, "**You have arrived on time, your flight may enter.**" If the flight arrives late, the mess checker will say, "**Your flight has arrived late, exit the dining facility immediately after receiving your MREs**". The mess checker will annotate the early/late flight and will issue one MRE per cadet in the flight. After the mess checker gives instructions, the Cadet Flt/CC will ask, "**Will that be all, SIR/MA'AM?**" After the mess checker responds, the Cadet Flt/CC will salute, return to the flight, and await entering the dining facility with normal building entrance procedures. When exiting the DFAC, cadets do not salute the mess checker.

3) The mess checker and cadet reporting in do not need to interrupt their reporting procedures to greet and salute commissioned staff. The area outside the dining hall will only be called to attention for colonels (O-6) and above. The first cadet to see one of these officers will call the area to attention, salute the officer(s), and render the greeting of the day. When the officer returns the salute the cadet will drop their salute and direct the area to carry on. When other commissioned officers approach, formation leaders will come to attention and call their formations to attention before rendering salutes.

c. Cadets must wash hands prior to entering the DFAC. At a minimum, cadets will use Liquid Hand Sanitizer dispenser located just inside the facility.

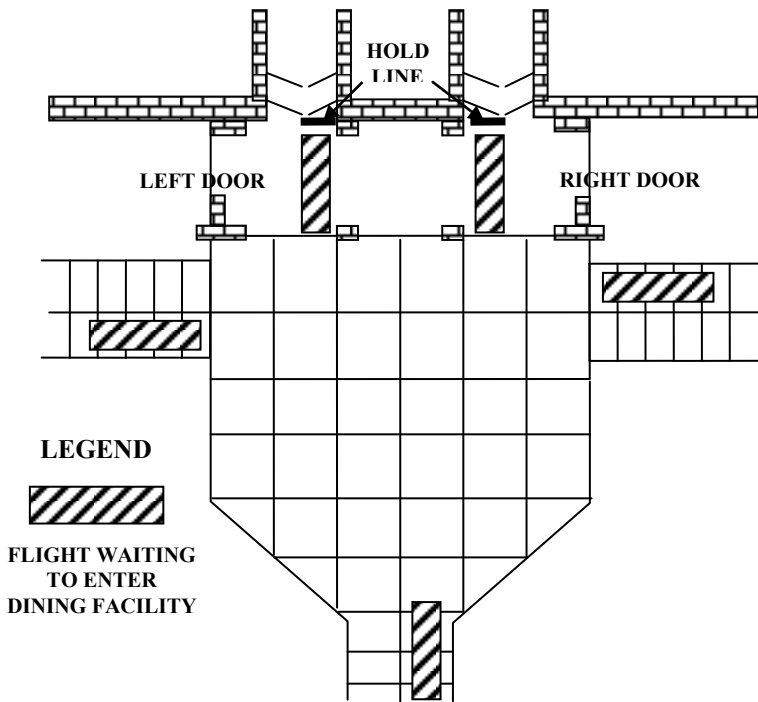

**FIGURE 9.1. Arriving at DFAC**

### **3. DINING FACILITY PROCEDURES**

a. Upon entering the dining facility form **two** lines even with the edge of the wall and remain at attention. Before moving forward, cadets will look both ways and then proceed into the serving area. While moving in the DFAC, cadets may not talk or look around unless addressed by a staff member or dining facility staff. Cadets may pass each other in the serving area if they are not waiting for the same food items. Cadets must execute proper situational awareness to ensure that they do not run into or obstruct the path of one another while moving through the dining facility. (NOTE: Cadets will not square corners while carrying trays, but will square corners in non-carpeted areas if unencumbered.) The Cadet FLT/CC will sign in for the entire flight. The Cadet FLT/CD will be the first to process through the chow line, and the Cadet FLT/CC will be the last. See Figure 9.2.

**b.** If a cadet needs to use the restroom, they will proceed directly to the restroom once they've entered the dining facility. Upon exiting the restroom, they will go to the back of the line waiting to post into the serving line.

**c.** Upon reaching the tray and silverware stand, cadets will step forward, execute a facing movement, and take a tray along with the appropriate silverware. Cadets will not step forward unless there is room on the serving line to place the tray. Cadets will not perform facing movements while in the serving line—they will side step through the entire serving line (heels together when halted). When using the salad bar and water fountain, cadets will go to the farthest available serving area in order to minimize backup. All cadets will consume a minimum of three full 8-oz. glasses of drinking water or sports drink per meal (24oz). Cadets may have juice, coffee, etc. in addition to the required liquids.

**d.** Tight meals are designed to instill self-discipline, a sense of military bearing and individual attention to detail. Tight meals include no talking or looking around. All cadets start eating tight meals beginning with their arrival and end eating tight meals as described in this section. The following guidelines apply whether or not a cadet is eating. Tight meals, by definition, include sitting at the position of modified attention.

(1) Cadets will sit at attention with back straight (not resting on the chair back) and shoulders squared. Elbows will not be placed on the table or chair arms. If leaning forward is needed to prevent spilling food, cadets will bend forward slightly from the waist, but not relax the position of attention.

(2) Cadets will not talk to each other at the table during a tight meal. Cadets may answer questions directed at them by staff or dining facility personnel. If addressed by a staff member with intent to engage in conversation that does not apply to on-the-spot corrections, cadets will finish swallowing, rise to the position of attention, and respond appropriately.

(3) Cadets will seat in accordance with Figure 9.2. When filling appropriate spots at a table, cadets will start with the lowest row and column numbers to the highest (starting with A1, going to A2, A3, etc).

(4) Once halted in position, cadets will ground the tray to the front edge of the table and centered and assume the position of attention. Cadets will remain at attention until the table is filled or a reasonable amount of time (20 seconds) has passed and then take a seat.

When the last cadet (position 4) arrives and stands at attention they will instruct the table to **“BE SEATED”**.

(5) All cadets will place Camelbaks and ponchos under their chairs and sit down. Once seated, cadets in positions 2 and 3 will pass a napkin to the cadet on their right and then take one for themselves. Napkins will be placed on the cadet’s lap.

(6) The cadet in Position 4 will state **“MOMENT OF SILENCE”** to accommodate those who wish to pray before their meal. When everyone at the table is ready, position 4 states **“Enjoy your meal”**.

(7) Cadets will place a napkin on top of the tray to signify they are finished with the meal.

(8) Cadets will have up to 10 minutes to eat their meal from the time the last person at their table sits down.

(9) Once everyone at the table has finished eating (all occupants of the table have napkins on their tray), cadets in Positions 2 and 3 will pass all the items from their trays to cadets in Positions 1 and 4. Trays will be stacked and carried to the cabinets by two when possible. If there are three cadets, one cadet will carry his/her own tray. If a cadet is unable to carry the tray due to restrictions, the other cadets will make the appropriate adjustments to carry the tray. Once trays are stacked, cadets will stand, don their Camelbaks, ground the chairs to the right side of the table, and then momentarily assume the position of attention. The cadet in Position 1 will proceed to the tray cabinet. The cadet in Position 3 will lift the napkin holder while the cadet in Position 2 wipes down the table. The cadet in Position 4 will wait to collect any waste left over from cleaning and then proceed to the tray cabinet. After complete position duties, cadets will proceed to the exit in a military manner.

#### 4. DEPARTURE PROCEDURES

(a) Cadet flights will exit the dining facility from the left side door (OTSAC side of the building) near the tray cabinets and march directly to the area near the flag pole. In higher FPCONs, when the side door is not available for use, flights will exit the dining facility through the front door on the side they entered, or as directed by the chow sharks.

(b) Cadets will form up in line formation in the designated area and wait for the rest of the flight to form up. The first two cadets in a flight to exit the Dining Facility will proceed to the front of the dining facility to retrieve the guidon and then fall in appropriately with the flight. When retrieving the guide the tallest cadet will be on the right and will carry the guidon.

(c) Crossing the Blue Line. The Blue Line painted outside the Dining Facility near the OTSAC provides a recurring reminder for cadets of their personal commitment to our nation, service, unit, and themselves. Do not step on the Blue Line at any time.

(1) Cadets will exit the Dining Facility or OTSAC and march as an individual or in details of two. (Details of three or four may not be used since the detail must be just one rank deep when crossing the Blue Line.)

(2) Cadets will march up to the Blue Line and halt just before crossing. When marching as a detail of two, the detail leader will command **“DETAIL HALT”** as needed to stop just in front of the Blue Line. While halted at the position of attention, each cadet will quickly recite the Honor Code, consider the Core Values, or think about what it means to be an officer.

(3) After this short pause (4-5 seconds), cadets will step across the Blue Line and continue forward. Detail leaders will use the command of **“FORWARD MARCH”** while individuals step across silently.

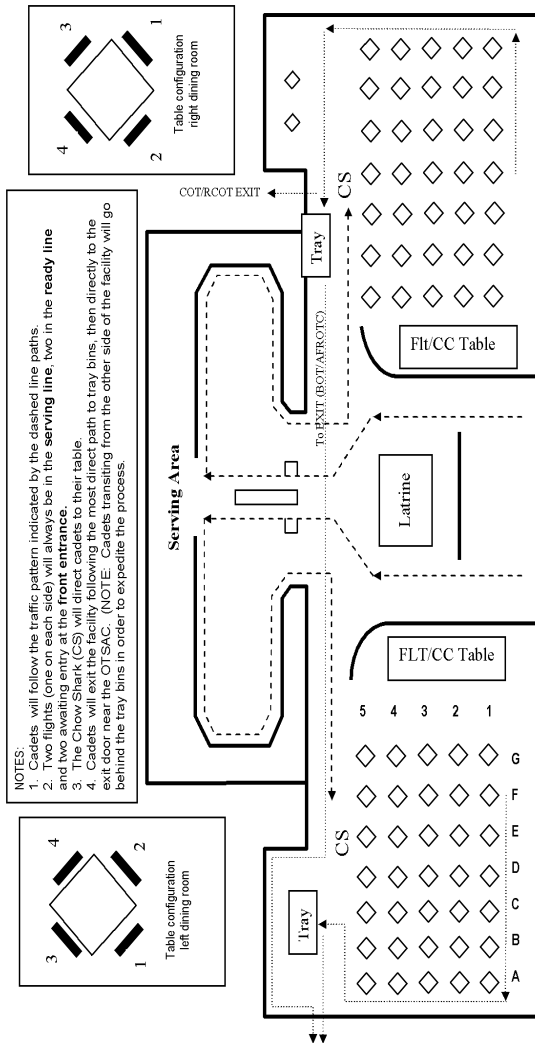

FIGURE 9.2 OTS DFAC interior

**1. GENERAL INFORMATION.**

**a. Housing.** While in garrison, you will be housed in OTS dormitories by flight in shared rooms. Remember that these dormitories also house OTS trainees, so be mindful to render proper customs and courtesies and display proper military decorum at all times. Female cadets will be housed in separate rooms from males. Unoccupied rooms and supply closets are off-limits unless a staff member specifically authorizes you to enter. Before entering a room occupied by members of the opposite gender, cadets and staff members will announce, “**Gentleman (Lady) in the area,**” and wait for the appropriate response. The cadet closest to the entrance will confirm that all cadets in the area are properly dressed and respond, “**Please Standby**” if any member is not properly dressed and, “**All Clear**” as soon as appropriate. Cadets will not change clothes in the presence of members of the opposite gender.

(1) **Dorm rooms.** Doors and blinds will be closed when cadets are changing clothes. Blinds will be fully open at all other times, and doors will be open at a 90° angle during duty hours and closed during sleeping hours (*Taps to reveille*)

**b. Inspection Order.** Rooms should be inspection ready from the end of the first dorm maintenance period until the beginning of CTQ. Wastebaskets must be completely empty during formal inspections and no more than half full at all other times.

**c. Common Areas.** Common areas are those spaces which all cadets use, i.e., stairwells, hallways, dayrooms, latrines, laundry rooms, etc. These areas must be clean and orderly at all times. Squadron Commanders will be responsible for all squadron common areas as designated by the group staff. The Group commander(s) will be responsible for common areas inside and outside of the main administrative building (including the laundry room).

(1) **Latrine.** Commodes, urinals, sinks, showers and drying areas will be kept clean and dry. Toilet seats will be displayed in the up position for both male and female latrines. Toilet tissue will be neatly rolled, i.e., not hanging down. Latrine doors will be opened 90 degrees when not in use.

(2) Windowsills, walls, stairwells, hallways, and water faucets will be cleaned on a regular basis.

(3) Personal or group-purchased commercial cleaning products are not authorized.

(4) Pictures, posters, etc., are not authorized for display in dorm unless approved by the Flt/CC.

**d. Energy Conservation.** Turn off all lights when not in use. Turn off water faucets when not in use and report leaks to the FLT/CC or CTA. Windows must remain closed/locked unless a staff member directs otherwise.

**1. BEDS - GENERAL GUIDELINES.** Keep bed rails clean and free from dust. Items placed on bed must be clean, dry, serviceable, folded, lint-free, and displayed tight, neat, and wrinkle-free where applicable. If an item becomes unserviceable, bring it to an Flt/CC or CTA's attention. Cadets who sleep on the bottom bunk will sleep with their head to the wall. Cadets who sleep on the top bunk will sleep in the opposite direction of the cadet in the bottom bunk. The bottom bunks will be utilized prior to the top bunks. The inspection side of the bed will be the center area between beds.

**a. Dust Cover Bed, Figure 11-1.**

(1) Bottom (First) Sheet. Drape evenly over width of mattress. Ensure the bottom edge of sheet is flush with the foot end of mattress. Tuck excess under at the head end of mattress. Make hospital corners.

NOTE: Making hospital corners. First, grasp the side of sheet approximately 12 inches from the head end of mattress; then, lay the sheet on top of the mattress, creating a 45-degree angle. Tuck excess hanging down, under mattress. Next grasp 45-degree angle and without changing its shape, bring it down and tuck under mattress. After sheet is completely tucked, smooth and tighten to the conformity of mattress.

(2) Top Sheet. Drape evenly over width of mattress so that the top edge of the sheet is approximately 6 inches from the head end of the mattress. Tuck excess under the foot end of mattress. Do not make hospital corners yet!

(3) First Blanket. Drape the blanket evenly over width of mattress, blue side up, tailored end to the foot of the mattress, and narrow end of blanket approximately six inches from the head end of mattress. Tuck the excess blanket under the foot end of mattress. Make hospital corners with both the sheet and the blanket, together. Tuck remainder of sheet/blanket under mattress. Smooth and tighten to mattress conformity.

(4) Pillow and Pillowcase. Put pillow inside the case and place between the first and top sheets. Center the length of pillow on the width of mattress, flush with the head end of mattress.

(5) Dust Cover. Fold the blanket in half from narrow end to narrow end, US insignia inside. Drape evenly over the head end of mattress. Single fold is approximately 24 inches from the head end of mattress.

Tuck excess blanket under the head end of mattress. Make hospital corners (picture does not show them). Ensure no excess blankets/sheets or strings are hanging down under mattress.

(6) Mattress. Center the mattress on the bed frame and ground to the head end of bed.

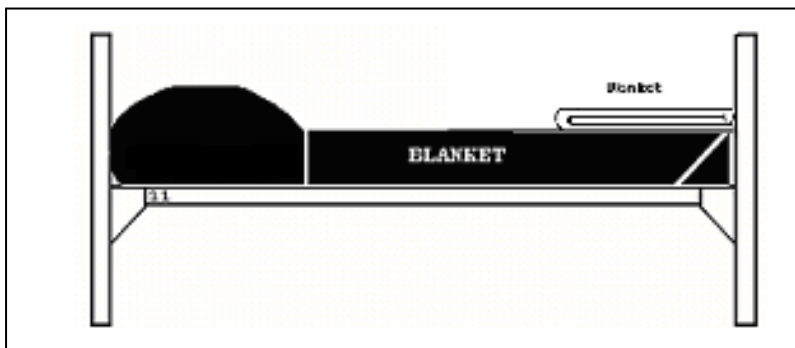

**FIGURE 11-1. Maxwell Dust Cover Bed (disregard e-fold blanket)**

**b. White Collar Bed, Figure 11-2.** Used during formal inspections. When making this bed, use instructions for “Dust Cover Bed” up to and including the placement of the first blanket, then proceed with the following steps:

(1) White Collar. Fold the top sheet and blanket over together to form a six inch white collar and then fold again, so that the bottom of the six-inch collar is 24 inches from the head end of the mattress. Make hospital corners. Tuck remaining material hanging on the sides neatly under the mattress, including white collar. After the blanket and sheet are completely tucked, smooth and tighten to conformity of mattress.

(2) Pillow and Pillowcase. Put pillow inside case. Center length of pillow on width of mattress, flush with the head end of mattress. The open end of pillow case faces away from the inspection side with the excess material neatly folded underneath.

(3) Mattress. Center the mattress on the bed frame and ground to the head end of bed.

(4) Extra Blankets. Place extra blanket(s) (if applicable) at the foot end of the mattress. Fold blanket(s) into an “e” fold and display with the single fold facing the foot end of the mattress. The blanket(s) should be flush with the foot end of the mattress. The “e” fold should be viewed from the inspection side of the bed.

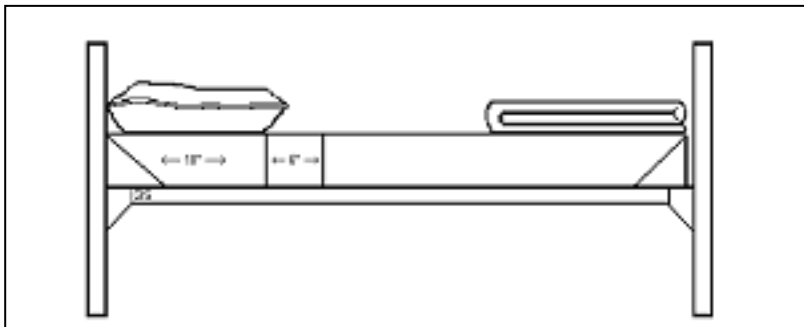

**FIGURE 11-2. White Collar Bed**

**c. Open-air Bed (during linen exchange), Figure 10-3.** Remove the blankets, sheets, pillow, and pillowcase from bed. Remove mattress cover only if exchanging. Otherwise, leave cover on mattress; tie strings if possible and tuck excess material underneath. Smooth and tighten to conformity of mattress.

(1) Mattress. Center the mattress on the bed frame and ground to the head end of the bed.

(2) Blankets. Fold blanket(s) not being exchanged into “e” fold, see **Figure 11-4**, using the following procedures: Stand on inspection side of bed and drape blanket evenly over the width of mattress. Place the narrow edges to the left and right; U.S. insignia (if applicable), facing up. Fold the blanket in half from right to left so insignia is inside. Second, fold the blanket in half from inspection side of bed to opposite side. Fold in thirds from left to right. When properly folded, “e” fold will be visible when viewed from the inspection side of bed.

(3) Placement. Stack blanket(s) on the mattress, if applicable - widest blanket on the bottom at foot end of the bed. Flush the blanket(s) to the foot end of mattress. Ground the blankets to the edge of mattress. Ensure “e” fold(s) are flush with each other and with the edge of the mattress on the inspection side.

(4) Pillow. Place pillow on top of blanket(s) centering length of pillow on the width of mattress. Flush the side of pillow with the single fold of blanket(s) and ground to edge of mattress.

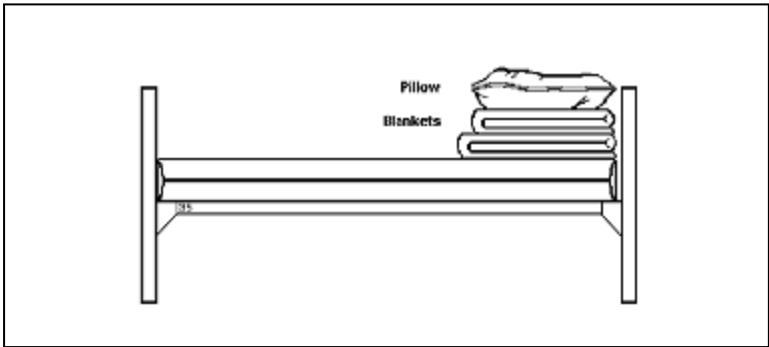

**FIGURE 11-3. Open-Air Bed**

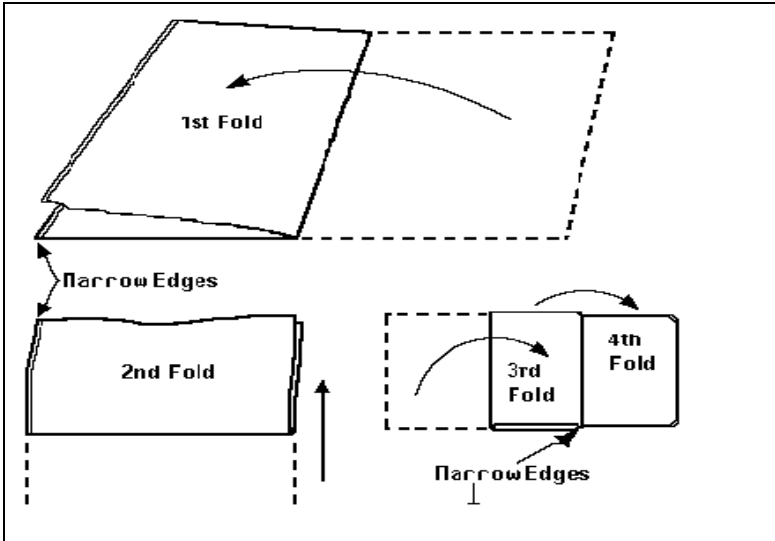

**FIGURE 11-4. Procedures for Making an “e” Fold**

**NOTE:** This illustration depicts how to create an “e-fold” with your blankets. The e-fold is used in the White Collar Bed display as well as in the Open-Air Bed display. There should be no “overbite” or “underbite”. All edges of the e-fold should be flush to each other.

**2. AFROTC IMTs 84M / 84-1M, *Dormitory Checklist of Authorized Items (Male/Female)*.** Cadets will display the appropriate IMT Inspection Checklist on their bed from wake-up until CTQ each day. All cadet information must be completed in displayed forms. On the Dust Cover Bed, the form will be centered under the dust cover, or crease, with the header information (top two inches approximately) displayed. Only the bottom two inches will fit under the crease. On the White Collar Bed the form will be centered under the bottom edge of the white collar with the header information displayed. On the Open Air Bed, the form will be centered under the bottom blanket with the header information displayed.

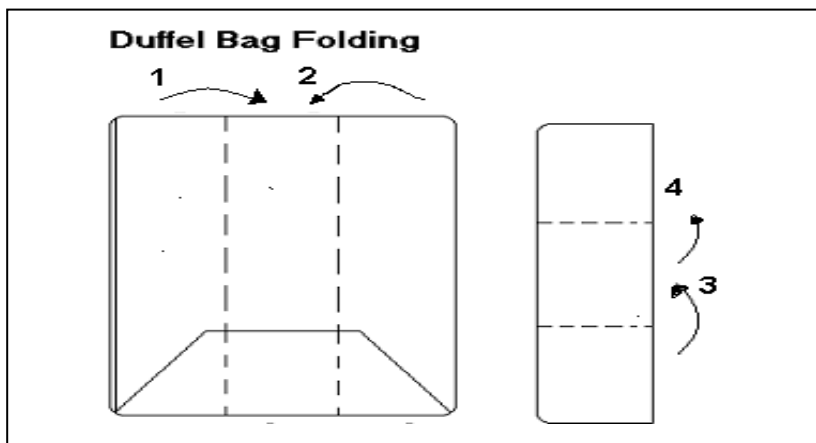

**FIGURE 11-5. Procedures for Folding a Duffel Bag**

**3. CLOSET.** For rooms with 3 or more cadets, cadets who are bunked together will share a closet. Cadets on the bottom bunk will use the left side of the closet and cadets on the top bunk will use the right side of the closet.

**a. General Instructions.** Keep the closet clean and dust free. Keep all items clean, dry, pressed, folded, serviceable, and displayed appropriately. Inform your Flt/CC or CTA if an item becomes

unserviceable. Remove all strings and tags (except sewn-in tags). Ensure all pockets are empty. Display items as worn (zipped, snapped, buttoned, pressed, etc.), unless otherwise directed. Exception: Special display uniform will be displayed as directed.

(1) Hang all hangers with the open end of hook facing toward the rear of the closet.

(2) Hang all items separately.

(3) Hang all sleeved items with the left sleeve facing the door of the closet.

### **b. Hanger Management**

(1) No more than three “extra” hangers are authorized for display in the closet. These hangers should be used for replacement purposes, to display the uniform of the day, or for items being worn or laundered.

(2) Display “extra” hangers as one, grounded to the left wall, and consider them as part of the wall itself.

(3) Overstocking hangers is not authorized. Excess hangers will be recycled (via dry cleaners) or disposed of.

### **c. Hanger Spacing**

(1) One cadet per closet: Space hangers evenly between the left wall and the right wall of closet. The space between the left wall and first hanger, and between the last hanger and right wall, is equal to the space between all other hangers.

(2) Two cadets per closet: Cadet using the left side of the closet will space hangers evenly between the left wall and an imaginary line in the center of the closet. Cadets using the right side of the closet will space hangers evenly between the right wall and the imaginary line in the center of the closet.

**d. Top Shelf, Left Side, Figure 11-6.** An imaginary line will be used in the center of the closet for closets with two cadets. In this case each side of the closet will have a “Top Shelf, Left Side.”

(1) Duffel Bag: When displayed, ground to the left side wall on the top shelf, single fold flush with front edge of shelf and handle on top. The “e-fold” will be to the viewer’s right. (see **Figure 11-5** for folding instructions)

(2) Flight Cap: Display with the back of cap flush with the front edge of shelf and ground, open end of cap to the left side of closet. Reference paragraph 5.d. (3) if issued and displaying a duffel bag.

(3) Soap and Soap Container: Soap must show signs of use and must be displayed in a container (exception to dry). Place the soap container where the left edge of container is 24 inches from the left wall and flush with the front edge of shelf. *One-piece container*: Leave lid open with hinges toward left. *Two-piece container*: Place bottom inside top. *Liquid soap*: Display upright, front facing forward, and flush with front edge of shelf.

**e. Top Shelf, Right Side, Figure 10-6.** An imaginary line will be used in the center of the closet for closets with two cadets. In this case each side of the closet will have a “Top Shelf, Right Side.”

(1) Spray starch (optional): Stand upright and ground to the back of closet and right wall. \*Note- Do not bring irons to Maxwell FTU, one will be provided per room.

(2) BDU/ABU Cap: Flush the bill of cap to the front edge of shelf and ground the side of cap to center partition.

(3) Flashlight: Place on shelf where the right edge of the flashlight is 12 inches from the right wall of closet; the wand-end will face to the rear; the butt-end will be flush with the front edge of the shelf.

(4) Rain Poncho: When dry, fold sides of rain poncho in towards center. With the hood away from you, roll the bottom of poncho towards the head hole. Tuck the rolled material neatly inside the hood. Place the folded poncho where the right edge is 18 inches from the right wall of the closet, the front of the poncho will be flush with the front edge of the shelf.

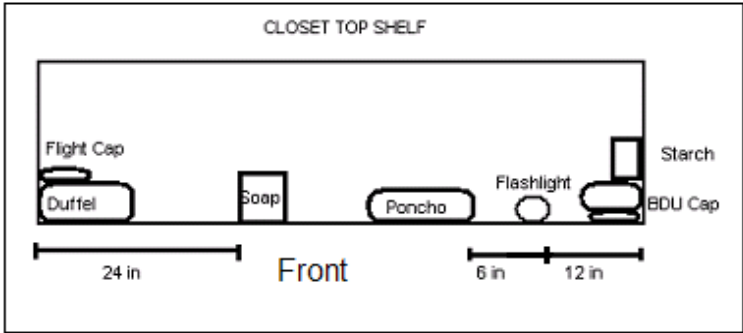

**Figure 11-6. Top Shelf; Shelf will be divided by imaginary line for closets with two cadets.**

#### **f. Hanging Arrangement**

(1) Rain Poncho: When wet, place on hanger and hang on shower rod with right sleeve facing in towards the shower. The spaces between the shower wall, hangers and shower door will be equidistant.

(2) Battle Dress Uniform (BDU)/Airman Battle Uniform (ABU): BDU/ABU shirts and pants will be displayed on separate hangers.

(a) The BDU/ABU shirts will be completely buttoned with exception of the top (collar) button. When properly displayed, front of shirt faces left side of closet and the left sleeve faces closet doors. Display all shirts next to each other, to the right of overcoat (if used).

(b) The BDU/ABU pants will be completely buttoned to include the inside flap. Place legs of pants inseam to inseam and drape over hanger bar. Cuffs should be even with waistband. When properly displayed, the fly of pants will face the closet doors, waistband faces left side of closet and cuffs face the right side. Display all pants next to each other, to the right of shirts.

(3) Short Sleeve Blue Shirts/Blouses: Leave top button unbuttoned and display so that the front of the shirt faces the left side of the closet.

(4) Blue Slacks: Place legs of slacks inseam to inseam and drape over hanger bar so waistband is to the left. Cuffs should be even with the waistband. Ensure each pair of pants is zipped, buttoned, and

hooked where applicable. Display the old style slacks first, then the new style, in order from left to right.

(5) Laundry bag: The laundry bag will be fastened to the hanging bar on the far right side of the closet or far right side against the imaginary center line for closets with two cadets. The center of the knot will act as the last hanger in the hanging arrangement, so the spacing must remain equidistant.

(a) To tie the bag, bring the neck of bag up behind the hanging bar, pulling it over the bar and toward you until 3 inches of the bag has cleared the top of the bar. Wrap cords around the bag twice, immediately above the open end of bag in the following manner: Take both cords behind the bag, and cross them. Bring cords around to the front of bag just above opening of bag, then pull cords tight and wrap them around bag a second time. Tie cords in a half-knot and allow the excess cords to hang straight down.

(b) The only items that will be displayed in the laundry bag are **dirty clothes** (ensure all pockets are empty), dirty towel(s) and dirty washcloth(s). A minimum of two and no more than four plastic bags (used for storing wet items and or an athletic supporter) is also authorized and mandatory. Use string, rubber bands, or twist ties to secure these plastic bags, whether they are full or empty. Mesh Bags are also required and will be stored in the laundry bag (a minimum of two). One bag will be used for black socks and dark-colored undergarments. Another bag will be used for white bras, light-colored undergarments, and white socks. These items **must** be in mesh bags when in the laundry bag. (Mesh bags will be issued by FT staff and are not yours to keep)

**4. SHOE DISPLAY.** Keep all shoes clean, dry, shined, serviceable, and displayed where applicable. If an item becomes unserviceable bring it to an Flt/CC or CTA's attention. Only one pair of running shoes will be displayed in the closet. If changing from the shoe of the day, place the shoes that were worn back in the closet in the appropriate order of display, loosely laced. Shoetrees may be placed in tightly laced shoes only; shoetrees not in use will be stored in the bottom clothing drawer. Exception to shined, clean and dry: Exchanged shoes may be scuffed, dirty or wet for remainder of training day they were used. No socks may be stored in shoes.

**a. Order of Display:** One cadet per closet: For closet doors that open to the right, the shoes will be displayed on the left wall. For closet doors that open to the left, shoes will be displayed on the right wall. If

there are two cadets per closet, cadets will use wall on their side of closet. The display will start in the rear corner of the closet (on the respective wall) starting with the Combat Boots, followed by the Low Quarters, Shower Shoes (soles must be made completely of rubberized material), the extra pair of running shoes (optional), and finally the running shoes. If removing a pair of shoes from display, close up space by sliding the remaining shoes toward the rear wall.

**b. Alignment:** Align shoes so that the longest pair of shoes will be grounded against the back wall and an imaginary line will be drawn parallel to the rear wall and perpendicular to the toe of the longest pair of shoes. Ensure heels and soles of like shoes are grounded to each other and unlike shoes are grounded at the soles only. Keep shoes as perpendicular to the imaginary line as possible.

**c. Lacing.** During the training day, display shoes tightly laced to the conformity of the foot. From CTQ until wakeup (night display), loosely lace all footwear so the foot slides easily into them. Tuck excess laces inside. Laces should not hang out of any shoe when displayed (day or night). NOTE: During emergency evacuation, use combat boots, low quarters or running shoes only. **DO NOT** wear soft-soled shoes during emergencies.

(1) Combat Boots with loops: Start at bottom loops, insert laces from bottom of loop, cross laces at each successive loop until the boot is completely laced. Tie a single knot at the end of each lace. Tighten laces to foot conformity and tuck excess laces inside boots, out of sight.

(2) Combat boots with eyelets: Lace with a bar at bottom. Insert laces through the bottom eyelets from the outside to the inside. Cross laces at each successive eyelet from the inside to the outside until the boot is completely laced. Tie a single knot at the end of each lace. Tighten laces to foot conformity and tuck excess laces inside boots, out of sight.

(3) Low Quarters: Lace with a bar at the bottom and an “X” at the top. Insert laces through the bottom eyelets from the outside to the inside. Cross laces at each successive eyelet from the inside to the outside stopping at the next-to-last eyelet. To form the “X” at the top, cross the laces at the top eyelet from the outside to the inside. Tighten laces to foot conformity and place excess laces inside the shoe, out of sight.

(4) Running Shoes: Lace in the same manner as low quarters; however, an “X” at the top is not required.

**5. SECURITY DRAWER.** Personal items will be placed in the bottom drawer of the chest of drawers. The security drawer must be kept locked with a combination lock when the owner is either out of the room or sleeping. The display must present a clean and professional appearance.

**6. PERSONAL HYGIENE DRAWER, Fig 11-7.** The second drawer from the bottom of the chest of drawers is used to display mandatory hygiene items. Display a **white** towel as a liner for the bottom of the drawer. Ensure it is clean, wrinkle free, and the laundry mark (if applicable) faces down. Fold the towel to fit inside the drawer by turning the sides and excess material underneath.

(1) Electric Razor: Remove the blade cover, if applicable, and wrap the cord around razor, securing it to itself. Don’t use string or rubber band to secure the cord. If cord is detachable, store it separately in the left half of the drawer. Display razor approximately centered between the front and rear of the drawer with the blade (head) down, and facing toward the rear of the drawer. Ground the razor to the left side of the drawer.

(2) Manual or disposable Razor: Remove the blade cover, if applicable. Display razor approximately centered between the front and rear of the drawer with the blade (head) down, and facing toward the rear of the drawer. Ground the razor to the left side of the drawer. Leave the blade cover on all extra disposable razors or, if using manual razor with disposable blades, leave the extra blades in container.

(3) Shampoo: Display the shampoo approximately centered between the front and rear of the drawer with the cap facing the rear of drawer. Ground the shampoo to the right side of drawer (lengthwise).

(4) Toothbrush/Case: Place toothbrush inside toothbrush case with head of brush toward the rear of the drawer and bristles facing the right side of drawer (exception to dry). Display the toothbrush case approximately centered between the front and rear of the drawer, and evenly spaced between the left and right side of the drawer. NOTE: For two-piece cases, insert the bottom into the top. For tubular cases, separate two pieces approximately 1/4 inch to allow for drying. For one-piece cases with hinged lids, leave open with hinges facing the left side of drawer.

(5) Toothpaste: Cap faces to the left; ground container to the right side and rear of drawer (lengthwise).

(6) Deodorant: Top faces to the left; ground container to toothpaste and to right side of drawer (lengthwise).

(7) Shaving Cream, Powder, or Pre-electric Lotion (males only): Top faces to the left; ground container to right side and front of drawer (lengthwise).

(8) Hairbrush (females/optional): Ground to front, right side of drawer with bristles up and handle to the left.

(9) Comb or pick (optional): If used, display comb or pick, grounded to the hairbrush (females) or the shaving cream, powder, or pre-electric lotion (males). Also, ground the comb or pick to the right side of drawer with the handle toward the left. Display the teeth of the comb facing the rear of drawer and the teeth of the pick toward the right side of the drawer. If no hairbrush (females), ground comb or pick to front and right side of drawer.

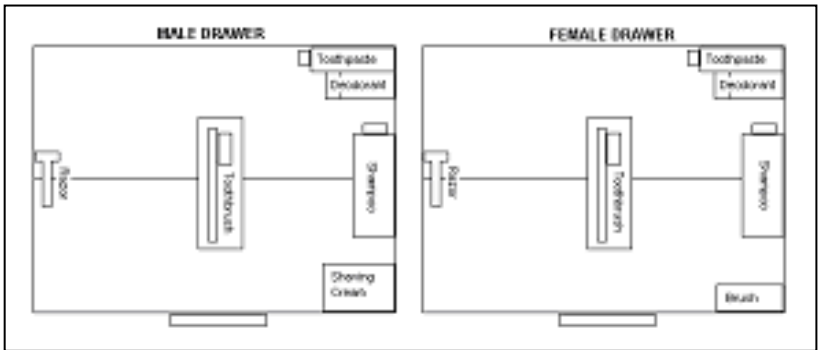

**FIGURE 11-7. Personal Hygiene Drawer**

**7. CLOTHING DRAWERS.** Keep drawers clean and all items in the drawers clean, dry, serviceable, folded, and displayed, where applicable. Stack like items with the largest item on bottom. If an item is not available for display, leave that space empty. Remove loose strings and tags. Do not remove sewn-in tags. Display items right side out. DO NOT iron clothing drawer items.

**a. TOP CLOTHING DRAWER, Figure 11-8.** The top clothing drawer will be the top drawer.

(1) Underwear (including boxer shorts, if applicable). Lay underwear flat with the front down and waistband away from you. Then fold in half from crotch to waistband. Finally, starting with the left side, fold sides toward the center in thirds. With the front facing up and waistband toward the rear of drawer, ground underwear to the right side and rear of drawer.

(2) Socks (wool/cotton). Fold each sock separately. Lay the sock flat with the heel up and open end away from you. Lay the heel flat. Fold sock in thirds from toe to open end. Socks will be stacked and sized individually. Socks will be displayed with the open end down and grounded to the rear of the drawer, single fold to the front. Ground cotton socks to the underwear, and wool socks to the cotton socks.

(3) T-shirts. All T-shirts are folded the same way. Lay the T-shirt flat with neck down and to the right. Fold each sleeve toward center, squaring the shirt. Keeping the neck centered, start with side closest to you and fold each side toward the center, until it is approximately six inches wide. Fold T-shirt in half from left to right twice. Stack and size T-shirts with the neck up and facing the front of drawer single fold to the front of drawer. Ground the brown/sand T-shirts to the front and right side of the drawer. The white T-shirts will be grounded to the front of drawer and to the brown/sand T-shirts. White T-shirts are mandatory for both male and female cadets and are to be folded the same as the brown/sand T-shirts.

(4) Bras. (Females only) For women, bras and sports bras will be folded neatly with straps and tags tucked underneath cups and grounded to the rear of the drawer and to the wool socks.

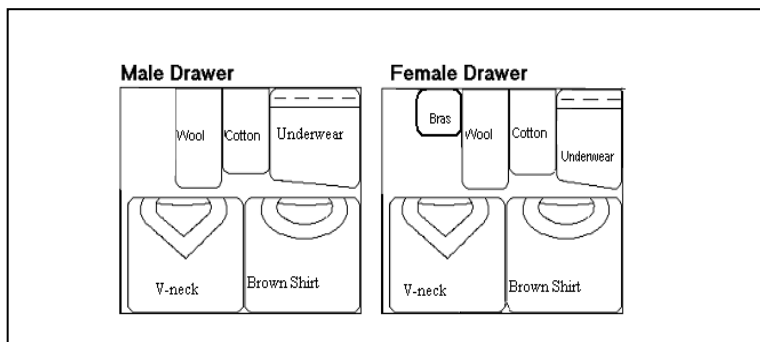

**Figure 11-8. Top Clothing Drawer**

b. **BOTTOM CLOTHING DRAWER, Figure 11-9.** The bottom clothing drawer will be the second drawer from the top.

(1) Towels. Lay bath towel flat with laundry mark facing down (if applicable). Starting with side closest to you, fold the towel away from you until it is approximately 12 inches wide. If necessary, fold overlapping edge back toward you to ensure approximately 12-inch measurement. Next, fold the towel in half toward you so that it is approximately six inches wide. Finally, fold the towel in half from left to right twice. Towels will be stacked and sized individually, with the largest towel on the bottom. The single fold will be grounded to the front of drawer, with side of towel grounded to left side of drawer. Excess clean towels will be displayed on the alcove shelf.

(2) Washcloths. Lay washcloth flat with laundry mark (if applicable) facing up. Fold in half from left to right, then in half from bottom to top. Ensure edges are as even as possible. Washcloths will be placed on top of the towels, grounded to the front left corner of the drawer, with the single fold to the front.

(3) Shoetrees (optional). Display shoetrees grounded to the right rear corner of the drawer. The toe of the shoetree will be to the right.

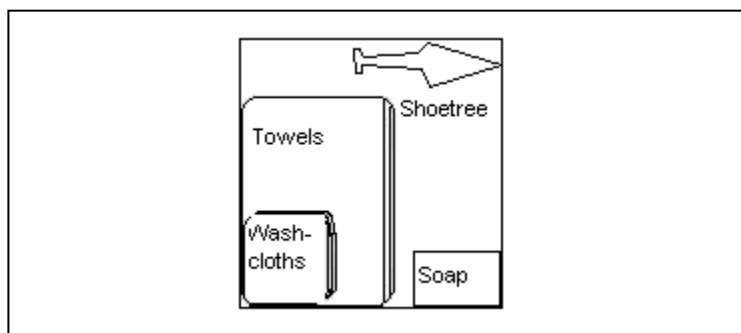

**FIGURE 11-9. Bottom Clothing Drawer**

**8. BED DRAWERS.** Cadets in the top bunk will use the right bed drawer as viewed from the inspection side of the bed and cadets in the bottom bunk will use the left bed drawer as viewed from the inspection side of the bed.

**a. General Instructions:** Keep the drawer clean and all items in the drawer clean, dry, serviceable, folded, and displayed, where applicable. If an item becomes unserviceable bring it to an Flt/CC or CTA's attention. If an item is not available for display, leave that space empty. Remove loose strings and tags. Do not remove sewn-in tags. Display items right side out. Do not iron bed drawer items.

**b. Bed Drawer, Fig 11-10.**

(1) T-Shirts: Extra white and brown/sand t-shirts, which do not fit in clothing drawer, will be grounded in the left rear corner with collars on the back wall. Brown/sand shirts will be on the bottom with white shirts on top.

(2) PT Shirt: Fold PT shirts in the same manner as other T-shirts. Place them in the drawer grounded to the back and in the middle of the drawer.

(3) PT Shorts: Lay shorts face down with the waistband away from you. Fold crotch up to waistband. Square shorts by folding in the sides. Fold in thirds starting with the left side. Turn shorts over so the front is facing up. Waistband and bottom of the shorts should be straight and parallel to each other. Stack shorts neatly in an alternating pattern atop PT Shirts. The bottom (single if one is being worn) pair of shorts should have the waistband grounded to the back of drawer in the center of the PT Shirts.

(4) Shoeshine Kit: Grounded to the right rear corner.

(5) PT Towels: Clean PT towels will be displayed in the right front corner of the drawer. The single fold will be grounded to the right wall and open ends grounded to the front wall (clean edges facing rear of drawer). They will be folded in the same manner as the bath towel.

(6) Socks: Fold socks in same manner as cotton/wool issued socks. Ground socks to the right side of the drawer and top of the PT Towel. If no PT Towels, ground to the right front of drawer.

(7) Study Materials: Stack neatly with largest object on the bottom and ground to the front and left sides of the drawer.

(8) Sunscreen/Bug Spray: Sunscreen will be grounded lengthwise in the front left corner with the cap facing the rear of the drawer. Bug spray will be grounded to the sunscreen and front of the drawer in the same manner.

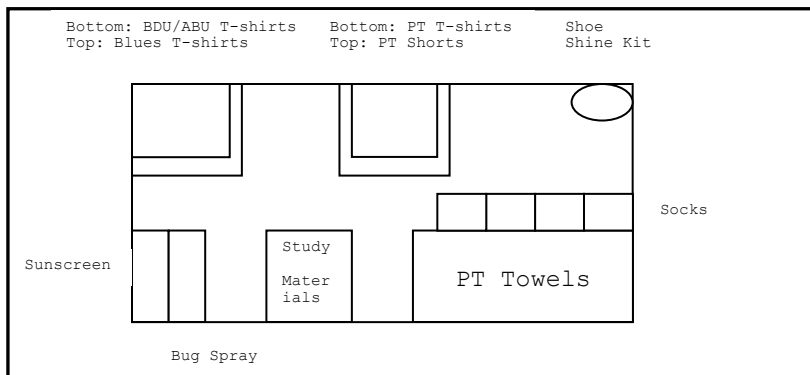

**FIGURE 11-10. Bed Drawer**

## 9. SPECIAL DISPLAYS

### a. General Instructions

(1) Items must be clean, dry, pressed, serviceable and properly displayed where applicable. If an item becomes unserviceable, bring it to the attention of an Flt/CC or CTA.

(2) Special Display Uniforms will be displayed during duty hours (i.e., from Wake-up until CTQ). *Unless/until worn, one BDU/ABU and one Blue Service Uniform will be displayed as a Special Display Uniform.* Display shirts and pants of like uniforms on the same hanger.

(3) Special displays that will be hung in a locker or closet will be hung to the left of that particular uniform's hanging display.

## **b. BDU/ABU Special Display**

### (1) Pants:

(a) Display the belt in loops, unbuckled.

(b) Drape pants over hanger bar so that legs are seam to seam with the waistband to the left and the fly towards the front of the closet. Place waistband and cuffs even. The fly is displayed unzipped/unbuttoned.

### (2) Shirt:

(a) Drape the shirt over the same hanger as pants with the right sleeve towards rear of the closet.

(b) Leave the front of the shirt and sleeves unbuttoned.

## **c. Blues Special Display**

### (1) Slacks:

(a) Display the belt in loops, unbuckled.

(b) Drape slacks over hanger bar so that legs are seam to seam with the waistband to the left and the fly towards the front of the closet. Place waistband and cuffs even. The fly is displayed unzipped/unbuttoned.

### (2) Shirt:

(a) Drape shirt over the same hanger as slacks with the right sleeve towards the rear of closet.

(b) Leave front of shirt and sleeve buttons (if applicable), unbuttoned. Pocket buttons must be buttoned. Shirt garters (if used) must be displayed.

(c) Nametags are mandatory and must be displayed appropriately.

## **d. PT Uniform**

(1) Clean uniforms to be worn will be removed from the bed drawer immediately prior to use.

(2) PT uniforms (T-shirt/shorts) will not be worn for more than 2 consecutive training days. Only uniforms to be washed will be displayed in the laundry bag.

(3) PT uniform drying for two cadets per room:

(a) Drape the T-shirt over the top edge of the chair back with the front of the shirt facing toward the desk. Drape sports bras (females) on top of PT shirt.

(b) Display PT shorts on the seat of the chair with the front facing up.

(4) PT uniform drying for more than two cadets per room:

(a) Top bunk cadets will follow instructions in step (3).

(b) Cadets bunked below a top bunk cadet will drape the T-shirt over the left side of their bed footboard with the front of the shirt facing up. Display shorts over the right side of the bed footboard.

## 10. SUPPLEMENTAL INFORMATION

**a. 5-Drawer Dressers:** The four dressers will be grounded to the middle of the wall. All dressers will be grounded to each other except for 6 inches between the middle two. Cadets on the lower bunks will use the left dresser on their side and cadets on the top bunks will use the right dresser on their side.

**b. Camelbaks:** The Camelbak will be displayed in the middle of the dresser, with the top side grounded to the wall. At night, cadets will ensure the Camelbak is full for hydration purposes. Cadets will fall out in the morning for PT with full Camelbaks.

**c. Towels and Washcloths:** Wet towels will be folded in half, length-wise, with the laundry mark facing in with bottom edges even with each other. Cadets on the bottom bunks will hang the towel on the racks in the shower with the single fold grounded to the left side of the rack. Cadets on the top bunks will hang the towel on the racks above the sinks with the single fold grounded to the left side of the rack. Wet PT towels will be folded in half, length-wise, with the laundry mark on the inside. Cadets on the bottom bunks will hang their PT towel on the same rack as their bath towel with the single fold grounded to the right side of the rack. Cadets on the top bunks will hang their PT towels on the head board of their bunk with the single fold grounded to the inspection side of the bed. Wet washcloths will be folded in half, length-wise, with the laundry mark facing in. Cadets will hang washcloths on top of their bath towels with the single fold grounded the same as the bath towels.

**d. Desk / Desk Chair:** One desk will be pre-positioned in the room with its back against the wall and shall not be moved. No items will be stored in or on the desk and it must remain clean at all times. The desk chair will be placed in front of and facing the desks at all times.

**e. Bed Stands:** The bed stands will be kept clean and dust free at all times. No items will be stored on them except during CTQ.

Quotable (**k**):

*“War, once declared, must be waged offensively, aggressively. The enemy must not be fended off; but smitten down. You may then spare him every exaction, relinquish every gain, but ‘til then he must be struck incessantly and remorselessly.”*

Alfred Thayer Mahan

**CHAPTER 12: INSPECTIONS, EVALUATIONS, COUNSELING**  
**(k)**

**1. INTRODUCTION.** The FT staff will evaluate you through direct observation and by analyzing the results of your performance as compared to your peers. This assessment of your performance will determine your suitability for entry into the Professional Officer Course (POC) and your potential to commission as an Air Force officer. It will also affect your final ranking at the detachment and therefore your choice of careers in the USAF.

**2. FORMAL INSPECTIONS.** You and your flight will receive two types of formal inspections: stand-by and open ranks. Any FT staff member may conduct formal inspections.

**a. Stand-by Inspections in garrison.** Stand-by inspections evaluate the condition and appearance of your quarters and equipment. Separate guidance regarding stand-by inspections while at BT and CSJFTC will be provided upon arrival at those locations.

(1) All cadets will be at parade rest outside of their rooms. The Cadet FLT/CC and Cadet FLT/CD will meet the inspector as he/she enters the flight area. The Cadet FLT/CC will call the flight to attention, salute the inspector, and report, “**Sir (Ma'am), \_\_\_ Flight is prepared for inspection.**” The Cadet FLT/CD will accompany the inspector and record any discrepancies on individual cadets’ AFROTC IMT 84M (Males) and 84-1M (Females). Cadets will follow the inspector into their room while the inspector is inspecting.

(2) After the inspector has finished inspecting the rooms, the Cadet FLT/CC and Cadet FLT/CD will escort the inspector to the common areas. Common areas will be inspected on AFROTC IMT 85. If available, the SQ/CC should accompany the inspector during this portion of the inspection.

(3) When the inspection is complete, the Cadet FLT/CC will salute the inspector and report, “**Sir (Ma'am), all flight areas have been inspected.**” The flight will prepare for the next scheduled event upon the inspector’s departure. The Cadet FLT/CD will consolidate discrepancies on to the discrepancy roster and turn all AFROTC IMTs 84M and 84-1M into the Cadet FLT/CC immediately after the inspection.

(4) The Cadet FLT/CC will review and initial the consolidated Flight Standby Inspection Discrepancy Report. The Cadet FLT/CD

will turn this report in to the FLT/CC (NLT CTQ on the day of the inspection).

**b. Open Ranks Inspections.** Open ranks inspections focus on military bearing and personal appearance. You will be expected to follow these instructions for open ranks inspections while at BT and CSJFTC as well.

(1) Flights being inspected will march to the inspection area, position themselves at the proper location, and stand at parade rest. The Cadet FLT/CC will be posted six paces to the front of, centered on, and facing away from the flight. When the inspector approaches, the Cadet FLT/CC will call the flight to attention, salute the inspector, and offer a verbal greeting. The inspector will direct the Cadet FLT/CC to prepare the flight for inspection at which time the Cadet FLT/CC salutes the inspector and does an about face. The Cadet FLT/CC then gives the command “**Open ranks, march,**” and then immediately walks at a 45-degree angle to position him/herself one pace to the guidon bearer’s right side and then faces down the line. The Cadet FLT/CC then proceeds to align the flight starting with the First Element and ending with the Third Element.

(2) Once the flight is aligned, the Cadet FLT/CC positions him/herself 3 paces in front of the guidon bearer’s right side, facing down the line. The first element will now be three paces to the left of the Cadet FLT/CC. The Cadet FLT/CC will command “**Ready front.**”

(3) The Cadet FLT/CC takes one step forward, conducts a right face, and salutes the inspector (who has positioned him/herself immediately in front of the Cadet FLT/CC) and reports, “**Sir (Ma'am), \_\_\_ Flight is prepared for inspection.**” The inspector returns the salute and begins to inspect the Cadet FLT/CC.

(4) While the Cadet FLT/CC is being inspected, the Cadet FLT/CD takes one step to the rear, conducts a right face, and marches to a position one pace to the right and one pace to the front of the guide. He/she faces down line and prepares to record the inspection results.

(5) Once completed inspecting the Cadet FLT/CC, the inspector asks the Cadet FLT/CC to accompany him/her on the inspection. Both the Cadet FLT/CC and Cadet FLT/CD will accompany the inspector; the Cadet FLT/CD documents discrepancies on the ORI Discrepancy Roster.

(6) After being inspected, the Cadet FLT/CC executes a left face (down line) and commands, “**Second and third elements, parade rest.**” The inspector takes the necessary steps forward to inspect the guidon bearer. The Cadet FLT/CD, who is still positioned in front of the guidon bearer, continues to face down the line. The Cadet FLT/CC executes a half left in marching without arm swing and halts one pace to the right and one pace to the rear of the inspector. (This causes the Cadet FLT/CC to precede the inspector and the Cadet FLT/CD to follow the inspector.) Cadet FLT/CD continues to face the inspector during the inspection, documenting any discrepancies. These positions are maintained throughout the inspection of the front of each respective rank. After completing the front inspection of each cadet, the inspector looks to the right to signal to the Cadet FLT/CC he/she is ready to move. When moving from individual to individual during the inspection, the inspector and Cadet FLT/CC simultaneously execute a facing movement to the right in marching and an in-place halt as described in section 7 below. (Cadet FLT/CD faces the inspector and simply takes one step forward for each inspector and Cadet FLT/CC movement)

(7) The movement is executed by pivoting 90 degrees to the right on the ball of the right foot, simultaneously stepping over the right foot with the left foot and placing the left foot parallel to the rank being inspected. Then advance one short step with the right foot, and place the right foot pointed toward the flight. Next bring the left heel into the right heel, and once again reassume the position of attention. The upper portion of the body remains at the position of attention, and the arm swing is suspended throughout when inspecting the front of each rank.

(8) These movements should place the inspector directly in front of the next individual to be inspected, still preceded by the Cadet FLT/CC and followed by the Cadet FLT/CD. After the inspector has inspected the last individual in the front rank, the Cadet FLT/CC hesitates momentarily and allows the inspector and Cadet FLT/CD to precede him or her as the inspector inspects the front rank from the rear. During the inspection of the rear of each rank, the Cadet FLT/CD follows the inspector approximately two paces to the rear, halting when the inspector halts. The Cadet FLT/CC will follow approximately two paces behind the Cadet FLT/CD, also halting with the inspector. After inspecting the rear of each rank, the inspector halts and turns in front of the element leader of the next rank. The Cadet FLT/CD marches past the rear of the inspector and reassumes the position following the inspector while the Cadet FLT/CC will halt and turn in front of the

second person in the next rank (the Cadet FLT/CC is once again preceding the inspector). (These procedures are used to inspect the front and rear of subsequent ranks.)

(9) When the inspection party finishes inspecting the first element and before the inspector halts in front of the first person of the second element, the second element leader assumes the position of attention. The element leader turns his or her head approximately 45 degrees down line and commands, **“Second element, Attention.”** When the first element leader can see the inspector out of the corner of his or her eye, the element leader turns his or her head down line and commands, **“First element, parade rest.”** This procedure is repeated throughout the remaining elements.

(10) After the last element has been inspected from the rear, with the Cadet FLT/CD and Cadet FLT/CC following the inspector, the inspector will halt and execute an about face. The Cadet FLT/CD will halt while the Cadet FLT/CC will position him/herself one pace to the right of the Cadet FLT/CD, halt, and record the inspection results of the Cadet FLT/CD. The inspector inspects the Cadet FLT/CD and commands **“POST”**. The Cadet FLT/CD will return to his/her position in the flight. The inspector marches off to the right flank (element leaders) of the flight while the Cadet FLT/CC proceeds directly to a position three paces beyond the front rank, halts, faces to the left (down line), and commands, **“Flight, attention.”** The Cadet FLT/CC then takes one step forward with arm swing and faces to the right. The inspector marches to a position directly in front of the Cadet FLT/CC and gives comments. After receiving comments, the Cadet FLT/CC will salute and greet the departing official appropriately, **“Good morning (afternoon or evening), Sir (Ma'am)”**. The inspector then executes the appropriate facing movement to depart. To conclude the activity, the Cadet FLT/CC will command, **“Close ranks, march”** before posting three paces in front of and centered on the flight. The flight will then be ready for the next scheduled activity.

### **3. INSPECTION GUIDELINES.**

**a. Stand-by Inspections in garrison.** Stand-by inspections evaluate the condition and appearance of your quarters and equipment. Any cadet who receives a total of four or more discrepancies in one or more of the four graded categories during a single stand-by inspection will be counseled via IMT 17. Stand-by inspections may occur at any time between the first session of dorm maintenance until the beginning of CTQ.

**b. Open Ranks Inspections.** Open ranks inspections focus on military bearing and personal appearance. Any cadet who receives a total of four or more discrepancies during a single open ranks inspection will be counseled via IMT 17.

**4. INFORMAL INSPECTIONS.** Unscheduled inspections are conducted by CTAs/Flt/CCs. CTAs/Flt/CCs will conduct a minimum of two informal inspections each week. Cadets who fail an informal inspection will be re-inspected by their Flt/CC within 48 hours. Cadets who fail two inspections will receive an AFROTC IMT 17 from the Flt/CC. Cadets who fail three inspections will be counseled by the FTU/COC. A fourth failed room inspection will result in an AFROTC IMT 17 from the FTU/DO who will make a recommendation to the FTU/CC to either retain the cadet or send the cadet home for unsatisfactory performance.

**5. DRILL EVALUATIONS.** In addition to the inspections, you and your flight will also be evaluated on drill. It is highly recommended that you study AFMAN 36-2203, *Drill and Ceremonies*, especially Chapter 4.

**a. Flight Drill Competition.** A flight drill competition is held during the in-garrison portion of Field Training. A flight leader will be selected by the flight for the flight drill competition (no cadet may serve twice).

(1) The flight leader will be handed a drill card and must lead the flight in the order the commands appear. The flight will have seven minutes to complete the movements within the confines of the 70' X 70' drill pad.

(2) The Cadet FLT/CC is responsible for marching the flight to the drill pad at the designated time. Upon arrival, the Cadet FLT/CC will ask the evaluator(s) for permission to enter the drill area.

(a) The Cadet FLT/CC will center the flight at the front of the drill pad, salute, and report to the evaluator, "**Sir (Ma'am), \_\_\_ Flight is present for drill competition.**" The Cadet FLT/CC will then call out the flight's selected leader for the drill competition.

(b) The chosen cadet will assume command, reposition the flight (approx. 30 seconds), salute, and report to the evaluator, "**Sir (Ma'am), \_\_\_ Flight is ready for drill.**" The evaluator will then provide the cadet a drill card, allow 30 seconds for review, and direct the sequence to begin. The chosen cadet has seven minutes to complete the drill sequence, reposition the flight, center him/herself three paces

in front of the evaluator, salute, and report, “**Sir (Ma'am), \_\_\_ Flight has completed the drill.**”

**6. EVALUATION.** Every aspect of your FT performance will be evaluated and recorded. Your Flt/CC and/or other commissioned FTU staff will complete several *Leadership Competency Evaluations* (LCE) of your actions and behaviors while serving in leadership positions and performing specific leadership tasks while in garrison, at BT, and at CSJFTC. Your Flt/CC will review this and other data, including PFA scores and academic test results, and complete a *Field Training Performance Report* (FTPR), which will be forwarded to your detachment commander. The FTPR is a permanent part of your cadet record. It will help your detachment commander determine your admission to and or continuation in the POC and your suitability for commissioning. Please see Attachments 2 and 3 for examples of an LCE and an FTPR. It is highly recommended that you arrive at your FTU familiar with these two forms, since they will determine your completion of, and ranking at, FT.

a. The FTU/COC evaluates Group Staff.

b. To successfully complete FT and enter the POC, you must receive an overall rating of satisfactory or greater on the FTPR.

c. To pass your final evaluation, your overall rating on your FTPR cannot be “Unsatisfactory” or “Marginal.” Non-contract cadets, receiving an overall unsatisfactory or marginal rating, will be removed from AFROTC. Contract cadets, receiving an overall unsatisfactory or marginal rating, will be reviewed by AFROTC/RR and investigated for disenrollment.

**7. COUNSELING.** During FT you will receive various counseling sessions. These sessions will provide you with information and constructive feedback allowing you the opportunity to understand how your performance is being perceived and if necessary, adjust that performance.

a. **Initial Counseling.** Your Flt/CC will conduct an initial counseling with you **NLT TD-3**. During this meeting, your Flt/CC will express his/her expectations for your performance. NOTE: The Flt/CC may allow cadets to conduct pertinent flight business while he/she is meeting individually with cadets.

**b. Mid-FT Counseling.** Mid-way through FT, you will receive a mandatory counseling session from your Flt/CC. During this session, your Flt/CC will identify your observed level of *Preparation for Field Training* and also advise you of your current *Strengths* and *Areas for Improvement*. For the areas for improvement, the Flt/CC will offer you suggestions for achieving the desired level of performance.

**c. Additional Counseling.** Your Flt/CC may schedule any additional counseling sessions he/she deems necessary in order to clarify expectations or discuss behavior or performance concerns.

(1) A number of items necessitate mandatory counseling by the Flt/CC using the AFROTC IMT 17 to include security drawer violations, formal inspection failures, lights out violations, and PFA failures.

(2) The AETC IMT 341 is given “on the spot” for unacceptable performance or behavior. Cadets receiving excessive amounts of AETC IMTs 341 will be counseled using AFROTC IMT 17. Examples include: arriving late to reveille or retreat formations; talking or making extraneous movements while at the position of attention; or failure to perform a particular duty such as knowing your daily knowledge.

(3) The FTU/DO and FTU/CC will counsel cadets referred as “Marginal” or “Unsatisfactory” by Flt/CCs as well as any cadets under investigation for significant breaches of discipline such as honor code or rules violations.

**d. Final Counseling.** Your Flt/CC will schedule you for a final counseling session no earlier than two days prior to your departure from FT. During this session, your *strengths* and *areas for improvement* will be highlighted on the FTPR. You will also receive your final PF ratings and your academic grade (if applicable). NOTE: The evaluation period does not end until you physically depart the FTU; your formal rating could change.

Quotable (k):

*“There is only one sort of discipline – PERFECT DISCIPLINE. Men cannot have good battle discipline and poor administrative discipline.”*

General George S. Patton, Jr., USA

## ***CHAPTER 13: PHYSICAL TRAINING (PT) (f)***

---

**1. OVERVIEW.** PT is an integral part of your FT experience and provides an opportunity to evaluate your physical condition and teamwork capacity. PT will occur daily and consists of such activities as the PFA, warrior runs, dynamic stretching, calisthenics, competitive sports, combatives, etc. To minimize the risk of injury, **CADETS MUST SHOW UP FOR FT ALREADY IN SHAPE.** Due to the strenuous nature of the new AEF focus, **ensure you bring two mouthguards already boiled and sized.**

**2. QUALIFYING FITNESS REVIEW (QFR).** Not earlier than 30 days prior to the end of the spring term, and not later than one day prior to departing for FT, cadets must pass the AFROTC Physical Fitness Assessment, which includes a body composition assessment.

### **3. PT SESSIONS.**

**a.** Fall in by squadron. Form up in column formation, without a guide. The class will form up with each flight facing their Flt/PFO. The squadrons are arranged in order as directed by the FTU staff during the initial PT lessons in Week 1. Prior to the start of the PT session, cadets will ground their gear. The gear will be standardized and grounded in straight lines. Spacing will be double arms length apart on each side and to the front and rear. The Cadet GP/ PFO ensures the group is at parade rest and prepared for the PT session prior to but not later than 0415.

**b.** Reporting Procedures. The Cadet GP/PFO initiates by commanding **“GROUP”**. The SQ/CCs will command **“SQUADRON”**, followed by the Cadet GP/PFO’s command **“ATTENTION”**. Starting with Squadron 1, each SQ/CC will salute the GP/PFO and say **“Ma’am/Sir, Squadron \_\_\_\_\_ is ready for instruction.”**

**c.** Class Procedures. The Cadet GP/PFO commands **“I am the center, FACE THE CENTER, FACE.”**

(1) The Cadet GP/PFO will announce warm-up exercises in the following manner: **“The first exercise of the day will be (exercise). It is a \_\_\_-count exercise. We will perform \_\_\_ repetitions. Position of the exercise, MOVE!”** All flights will then assume the appropriate

position. The Cadet GP/PFO will then give the command of execution, **“Ready, BEGIN!”**

(2) The Cadet GP/PFO will call cadence and each flight will respond on the completion of each set. Example follows.

Cadet GP/PFO calls, **“1...2...3...etc.”**

Cadets respond, **“ONE”**

Cadet GP/PFO calls, **“1...2...3....etc.”**

Cadets respond: **“TWO”**

(3) Note flight members do not recite, **“Air Power”** after every number the Cadet GP/PFO announces... only at the conclusion of each exercise.

(4) Following the completion of each exercise, cadets will respond as follows:

Cadet GP/PFO announces, **“RECOVER.”**

Cadets respond, **“AIR POWER!”**

**d.** For any exercise requiring a partner, flight members will be paired by gender (male/male and female/female). In the event there is an extra cadet, a CTA of the same gender or a member from a different flight may be used.

**e.** All cadets are required to bring a PT towel.

**f.** After the warm-up exercises, the FLT/PFO will move the flight to the starting point of the day’s physical activity.

**g.** Closing Class Formations. Fall in by flight and squadron. The Cadet GP/PFO will ensure everyone has put on their equipment and the formation is at attention. Then a member of the FTU staff will dismiss the entire formation.

#### **4. PFA**

**a.** PFA scores are calculated based on five weighted events: the abdominal circumference measurement, height/weight, push-ups, sit-ups, and a 1.5-mile run. To pass, you must achieve a composite score of 75 or greater:

**b.** An abdominal circumference and height/weight measurement will be accomplished during in-processing only; this portion of your score will not change during FT. As stated in AFI 10-248, if their BMI is below 25, they will receive the full points for the abdominal

circumference, but everyone will have an abdominal circumference measurement in the system.

c. Push-ups, sit-ups, and the 1.5-mile run will determine the remainder of your PFA score. Your first PFA score will determine your *Physical Fitness Assessment* PFR on your FTTPR.

d. Cadets must pass the PFA administered on TD-4. A “make-up” PFA will be administered on or about TD-8. Cadets, failing to meet this standard, will be removed with prejudice from the FTU. Cadets will have only two opportunities to meet this standard. Cadets failing the PFA during FT will receive a rating no greater than “Marginal” on the Physical Fitness Assessment PFR of their final FTTPR evaluation.

**5. CONDUCT OF THE PFA.** Conduct 5-10 minutes of warm-up exercises prior to the PFA. Warm-up exercises should not include events, which will stress muscle groups (i.e., push-ups, sit-ups, etc.). During the PFA, staff members will monitor each event to ensure standardization and proper execution. Incorrect repetitions of push-ups and sit-ups will not be counted, and the number of the last correct repetitions will be repeated until the cadet corrects the error. You will be told what you’re doing wrong until you correct the error. The total number of correct repetitions in one minute is recorded as your score.

**a. Push-ups:** From the starting position (arms extended, fingers pointed forward), the cadets will lower the body to the ground until the upper arm is at least parallel to the floor (elbow bent at least 90 degrees) before pushing back up to the starting position (the chest may touch the floor). If the cadet does not come down far enough, the push-up does not count. The cadet completes one full push-up after returning to the starting position. It is important to monitor the cadet’s form and make sure the body does not bow at the waist as the cadet tires. The body must remain rigid during the assessment (the back must remain straight unless resting). Cadets must keep hands and feet on the floor to rest (no shaking out hands or feet); any resting must be done in the “up” position.

(1) Completion of Exercise. 1-minute time limit expires; any hand or foot is removed from floor; cadet rests in the down position.

(2) Spotters. Kneel directly in front of the cadet. Count repetitions aloud each time arms extend fully to the up position.

**b. 3 Minute Rest minimum.**

**c. Sit-ups.** The starting position is lying on the floor with face up, knees bent at a 90-degree angle, and feet/heels in contact with the floor at all times. The heels and buttocks must remain on the floor during the entire assessment. The cadet's arms will be crossed over the chest with the hands at the shoulders or resting on the upper chest. A complete sit-up is accomplished when the upper torso of the cadet is raised off the floor, the elbows touch the knees or thighs, and the upper torso is lowered back to the floor until both shoulder blades touch the floor. Elbows must touch the knees or any part of the thighs at the apex of the sit-up, and the shoulder blades must touch the floor at the bottom of the sit-up. The hands must stay in contact with the shoulders/upper chest at all times (no pulling/grabbing of the shirt). The cadet may only rest in the "up" position. If the cadet rests in the down position, the test will be terminated. Also, do not rest by putting your elbows over the knees—hugging the knees.

(1) Completion of Exercise. 1-minute time limit expires; cadet rests in the down position.

(2) Spotters. The cadet's heels must remain anchored to the floor throughout the assessment. The cadet may request to have their feet held down with the hands or by putting knees on feet, but the monitor may not anchor the cadet's legs by holding onto the calves during the assessment. Enough force must be applied to keep the feet/ankles from rising while the sit-ups being accomplished.

**d. 3 Minute Rest minimum.**

**e. 1.5-Mile Run:**

(1) Acceptable. Walking at any time or momentarily stopping to re-fasten shoe lace(s) during the run, provided the cadet remains within the lateral limits of the running surface; signaling current lap count verbally or using fingers; wearing a watch; walking for one lap on the outside of the track to cool down after completing the 1.5-mile run.

(2) Unacceptable. Crossing an inside barrier (if present); deliberate physical contact with another runner or observer, regardless if the contact occurs on or off the running surface.

(3) Completion of Exercise. Crossing the finish line; failure to cross the finish line (regardless of reason) results in a score of zero for the event.

(4) Spotters. Must remain off the running surface; cannot physically aid or impede any runners on the track in any way; must remain focused on lap counts and time hacks.

(5) Observers. Must remain off the running surface. (i.e.; no pacers are allowed)

Quotable (**k**):

*“The power of excellence is overwhelming. It is always in demand, and nobody cares about its color.”*

-- General Daniel S. “Chappie” James, USAF

## **CHAPTER 14: FIELD TRAINING COMPLETION (i)**

---

**1. REQUIREMENTS.** To satisfactorily complete FT, you must complete at least 80 percent of the required training as specified in the *Field Training Syllabus* and not be absent from the FTU or on any physical profile for more than 72 consecutive hours. You must also pass the PFA; attain an 80 percent academic average (extended FTUs only); and not be rated as “Unsatisfactory” in any performance factor (PF) or receive an overall score of “Unsatisfactory” or “Marginal” on the Field Training Performance Report.

**2. NON-COMPLETION.** There are many reasons you may be released from FT without completing training requirements. These reasons may be within your control (removed with prejudice) or out of your control (released without prejudice). If you are removed or released, the FTU/CC (or delegate) will notify your detachment commander and observe while you contact a family member and inform them of your new travel itinerary. The FTU Staff will contact the appropriate base agency for those unable to travel (mental stress, fatigue, etc.). An FTPR will be accomplished for all cadets who report to the FTU.

### **a. Release.**

(1) **Administrative (Emergency Absence).** In the event of an emergency, the FTU/CC may authorize you to be absent from training for up to 72 consecutive hours. Note emergencies must be verified through the American Red Cross. If you cannot return within 72 hours or are unable to make up missed training to meet syllabus requirements, you will be released without prejudice.

### **(2) Medical Release.**

(a) Cadets placed on profile, preventing their active participation in PT, competitive sports or drill for a cumulative period of more than 80% of physical activity time (to include morning PT, LRC, confidence course, athletics, warrior competition day, warrior runs (not Flt/CC Time PT sessions), will be released without prejudice. If a session is cancelled, cadets will be given credit for having attended, whether on profile or not.

(b) Cadets medically restricted to quarters or admitted to the MTF for a cumulative period exceeding 72 hours, will be released without prejudice and sent home, even if they have successfully completed the PFA.

(3) **Did not Attend.** This classification applies if a cadet does not show up, whatever the reason, for the assigned FTU. Notify your Detachment as soon as you discover that you will be unable to attend Field Training. HQ AFROTC will determine if the cadet will be released with prejudice.

**b. Removal.**

(1) **Self-Initiated Elimination (SIE).** SIE means that you voluntarily withdraw yourself from FT. You will be counseled and must state your reasons for withdrawing in an official memorandum to the FTU/CC via the Flt/CC and DO. You must acknowledge receipt of the FTU/CC's comments by endorsement and will be removed with prejudice and will receive an "unsatisfactory" rating on your FTPR.

(a) If you are a contract cadet, you must understand that SIE will jeopardize your future status as a candidate for a commission in any branch of the US Armed Forces. It could also result in an involuntary call to extended active duty in your enlisted grade or recoupment of paid scholarship benefits.

(b) If you are a non-contract cadet, you must understand that SIE may jeopardize your future status as a candidate for a commission in any branch of the US Armed Forces.

(2) **Military Performance.** The FTU/CC is the local authority for removals based on "unsatisfactory" performance. Examples of cadets, removed with prejudice from an FTU for military performance, include but are not limited to: serious misconduct, lack of discipline, Honor Code violations, drug or alcohol involvement, indifference to training; or any time the FTU/CC determines you will not meet standards in one or more of the Performance Factor Ratings (PFR) on the FTPR.

(3) **Physical Fitness.** You must have passed the Qualifying Fitness Review (QFR) with a composite score of 75 or greater to attend FT; you must also achieve a composite score of 75 or greater on the PFA at your respective FTU in order to remain at and complete FT. Any cadet who does not pass one of the two PFAs offered will be removed from the FTU with prejudice and will be rated as "unsatisfactory" on the *Physical Fitness* PFR of the FTPR.

**1. INDIVIDUAL FIELD TRAINING AWARDS.** FT awards are given for exceptional performance at the FTU. FT awards are based upon specific FT criteria below or as determined by an FTU/CC directed awards board. Field Training staff can announce and recognize all award winners at the Awards ceremony except the Academic Honors Award which will be calculated and presented at the Detachment. CTA badges will be presented at the ceremony. However, all ribbons/medals will be presented at the detachments. Criteria for all awards can be found in AFROTCI 36-2020.

**a. Field Training Distinguished Graduate (FTDG) Award.** Cadets graduating FT in the top 10 percent of their flight at FT, as determined by the FTPR, will be designated as a distinguished graduate and will be awarded the FTDG ribbon (including silver star device). This ranking will be based on a cadet's FTM test score, PFA score, leadership position score(s), LRC score, AEF participation, and other evaluation points as determined by FTU staff. The top 10 percent is based upon flight end strength, to include those removed w/prejudice since TD-1, rounded down. Fractional percentages are calculated by the FTU to determine additional FTDG awards to be given by the FTU/CC.

**b. Field Training Superior Performance (FTSP) Award.** Cadets graduating FT in the next 10 percent below FTDG in each flight, as determined by the FTPR, will be designated as a superior performer and will be awarded the FTSP ribbon. This ranking will be based on a cadet's FTM test score, PFA score, leadership position score(s), LRC score, AEF participation, and other evaluation points as determined by FTU staff. The next 10 percent is based upon flight end strength, to include those removed w/prejudice since TD-1, rounded down. Fractional percentages are calculated by the FTU to determine additional FTSP awards to be given by the FTU/CC.

**c. Field Training Fitness Award.** The FT Fitness award recognizes one male and one female cadet in each FTU with the top PFA score at FT. All components of the PFA must be completed to qualify. In the event of a tie, cadets will be given additional points based on an extended PFA scale: 1 point for each pushup beyond the maximum; 1 point for each sit-up beyond the maximum; and 1 point for each 5 seconds faster than the maximum run time. The faster 1.5 mile

run time will be used to break any ties. The award recipient will receive the FT Physical Fitness ribbon and a plaque. Also, all cadets who score a maximum on the PFA run, push-up, and sit-up categories will be recognized with the Physical Fitness ribbon. NOTE: This is the same ribbon as the detachment Physical Fitness Award. Receipt of this award for FT is equivalent to one award at the detachment.

**d. AFROTC Expert Marksmanship Ribbon.** Cadets qualifying as expert on an approved USAF qualification range may wear the AFROTC Expert Marksmanship Ribbon. NOTE: Cadets will receive an AF IMT 522, **Ground Weapons Training Data**, documenting qualification for ribbon. See AFROTCI 36-2020, *AFROTC Cadet Awards and Decorations Program* for additional guidance on this ribbon.

**g. Warrior Spirit Award.** This award will be peer-nominated and recognizes the cadet in each FT flight who best exemplifies the Air Force warrior spirit. Criteria should include appearance, attitude, enthusiasm in duty performance, and physical fitness. Awarded to one cadet in each FT flight. Ties will be decided by the Flt/CC. NOTE: This is the same ribbon as the detachment Warrior Spirit Award. Receipt of one of these awards for FT is equivalent to one of the same award at the detachment.

**2. FIELD TRAINING FLIGHT AWARDS.** FT flight awards are given for exceptional flight (team) performance at FT. Criteria are listed below. NOTE: These are the same ribbons as the detachment Honor/Warrior Flight Ribbons. Receipt of one of these awards for FT is equivalent to one of the same award at the detachment.

**a. Field Training Honor Flight Ribbon.** Honor Flight will be calculated by the FTU/COC and may be based on the initial FTM test, flight drill evaluations, SBIs, and ORIs, LRC events, and/or other evaluation points as determined by FTU staff. The overall FTU winner will be awarded the Honor Flight Ribbon at their detachment.

**b. Field Training Warrior Flight Ribbon.** Warrior Flights may be based on flight performance on PFAs, select GLPs, Warrior Competition Day, AEF events, and/or other evaluation points as determined by FTU staff. The overall FTU winner will be awarded the Warrior Flight Ribbon at their detachment.

Quotable (k):

*“It is the soldier, not the reporter, who has given us the freedom of the press. It is the soldier, not the poet, who has given us the freedom of speech. It is the soldier, not the campus organizer, who has given us the freedom to demonstrate. It is the soldier who salutes the flag, who serves beneath the flag, and whose coffin is draped by the flag, who allows the protestor to burn the flag.”*

-- Father Denis Edward O'Brien, Sergeant, USMC

**ATTACHMENT 1: FTU Training Phases (i)**

**FTU TRAINING PHASES BY TRAINING DAY**

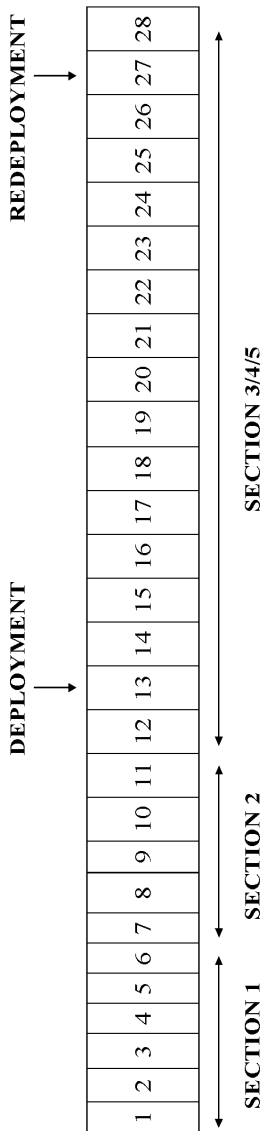

Airman's Manual SECTION 1  
Staying Ready, pp. 2-7

Airman's Manual SECTION 2  
Deploy, pp. 10-36

Airman's Manual SECTIONS 3/4/5  
Employment, pp. 38-80  
Fight, pp. 82-117  
Survive, pp. 126-193

## ATTACHMENT 2: Leadership Competency Evaluation (i)

<b>HOLM CENTER LEADERSHIP COMPETENCY EVALUATION</b>														
STUDENT NAME	SQUAD	EVALUATOR NAME	LEADERSHIP EXERCISE			DATE								
<b>A. LEADERSHIP COMPETENCIES</b>					INSTRUCTOR COMMENTS:									
<b>MANDATORY REQUIREMENTS</b>														
<b>I. CLEARLY RECOGNIZED THE MISSION/OBJECTIVE</b>										Y	N			
<b>II. MAINTAINED COMMAND OF TEAM MEMBERS</b>										Y	N			
										<b>U</b>	<b>S</b>			
1. Developed trust, credibility, and commitment through words and actions	1	2	3	4						5				
2. Delegated authority when appropriate <small>(DO NOT ABRIDGE COMMAND, see it above)</small>	1	2	3	4						5				
3. Displayed accountability for areas of responsibility, operation of team, and personal actions	1	2	3	4						5				
4. Demonstrated flexibility by adapting to changes	1	2	3	4						5				
5. Displayed military bearing, self-discipline, self-control, & confidence under pressure	1	2	3	4						5				
6. Articulated ideas and intent in a clear and concise manner	1	2	3	4	5									
7. Promoted free flow of communication and solicited feedback	1	2	3	4	5									
8. Motivated and inspired team to achieve objective	1	2	3	4	5									
9. Maintained focus and intensity	1	2	3	4	5									
10. Developed team by fostering cohesiveness and cooperation	1	2	3	4	5									
<b>Score</b>														
<b>B. DECISION ANALYSIS</b>					<b>U</b>	<b>S</b>								
1. OBSERVE	1	2	3	4	5									
2. ORIENT	1	2	3	4	5									
3. DECIDE	1	2	3	4	5									
4. ACT	1	2	3	4	5									
<b>Score</b>														
<p><b>OBSERVE</b></p> <p>Recognized the correct problem Clearly stated the problem Gathered data</p>					<p style="text-align: right;"><b>ORIENT</b></p> <p style="text-align: right;">Defined required performance levels Used brainstorming guidelines</p>									
<p><b>ACT</b></p> <p>Set plan into action Monitored implementation of the plan Corrected deviations from the plan Develop contingency plan(s) when needed Standardize best practices as appropriate</p>					<p style="text-align: right;"><b>DECIDE</b></p> <p style="text-align: right;">Tested solutions against established criteria Considered the feasibility or effectiveness of the solutions Determined necessary tasks, standards, responsibilities, and milestones.</p>									

<b>C. MISSION COMPLETION</b>		<b>Y</b>	<b>N</b>	<b>Overall Grade U M S H O</b>	
<b>Score</b>		3	0		
<b>Completion Time</b>				<b>Out standing</b>	> 64
<b>LEADERSHIP COMPETENCY SCORE</b>				<b>High-Satisfactory</b>	54-63
A. Leadership Competencies				<b>Satisfactory</b>	32-53
B. Decision Analysis				<b>Marginal</b>	23-31
C. Mission Completion				<b>Unsatisfactory</b>	< 22
<b>OVERALL SCORE</b>					
I have read and understand the comments regarding my performance. I do/do not wish to make a written statement.				INSTRUCTOR SIGNATURE	
STUDENT INITIALS		DATE			
<b>INSTRUCTOR/STUDENT COMMENTS:</b>					

### ATTACHMENT 3: Field Training Performance Report (i)

2008 Field Training Performance Report			
1. CADET NAME (Last, First MI)		2. FTU	3. FLIGHT
4. INCLUSIVE DATES			
5. EMPID	6. DET	7. LEADERSHIP POSITIONS HELD	
8. AWARDS EARNED			
<input type="checkbox"/> DISTINGUISHED GRADUATE	<input type="checkbox"/> PHYSICAL FITNESS	<input type="checkbox"/> HONOR FLIGHT	<input type="checkbox"/> EXPERT MARKSMANSHIP
<input type="checkbox"/> SUPERIOR PERFORMANCE	<input type="checkbox"/> FTU "IRON WARRIOR"	<input type="checkbox"/> WARRIOR FLIGHT	<input type="checkbox"/> ACADEMIC HONORS
	<input type="checkbox"/> WARRIOR SPIRIT	<input type="checkbox"/> TOP GUN	<input type="checkbox"/> CTA RECOMMENDATION
9. PERFORMANCE RATINGS: Unsatisfactory / Marginal / Satisfactory / Excellent / Outstanding			
A. PREPARATION FOR FIELD TRAINING: Initial Interview; Initial Open Ranks Inspection (ORI); Initial Stand-By Inspection (SBI); Initial Airman's Manual Test (AMT); Initial Field Training Manual Test (FTMT)			
Interview:                      ORI:                      SBI:                      AMT:                      FTMT:			
B. PHYSICAL FITNESS ASSESSMENT (PFA):			
Date	# Pushups	# Situps	Run Time      Ab. Circ      Score      Result
C. LEADERSHIP SKILLS: Problem solving ability; Coordination, Control, Delegating, Directing, Dynamic Leadership, Initiative; Performance of Duties; Followership/Team Player			
D. PROFESSIONAL QUALITIES: Officership (loyalty, discipline, dedication, integrity); Accepts personal responsibility; Attention to detail/situational awareness; Motivates others; Tact/Sensitivity; Attitude; Human relations			
E. COMMUNICATION SKILLS: Verbal/written; Clear, concise; Articulate; Confident			
F. JUDGEMENT AND DECISION MAKING SKILLS: Time management; Reaction to counseling; Uses resources effectively/efficiently; Learns from mistakes			
G. WARRIOR ETHOS: Adaptability to change/stress; Applies training to austere environments; Expeditionary skills adaptability			
Additional FTO Comments		OVERALL PERFORMANCE	
Name / Grade		Duty Title	Date
Det. / Location		Signature	
10. FTU/CC COMMENTS <input type="checkbox"/> Concur <input type="checkbox"/> Nonconcur			
Name / Grade		Duty Title	Date
Det. / Location		Signature	
11. ACADEMIC (EXTENDED FTUs ONLY)		12. PERFORMANCE WITHIN FLIGHT	
		<input type="checkbox"/> Bottom 1/3 <input type="checkbox"/> Mid 1/3 <input type="checkbox"/> Top 1/3	
			13. COMPLETION STATUS



# Sexual Harassment

A variety of BEHAVIORS						
VISUAL	VERBAL	WRITTEN	TOUCHING	POWER	THREATS	FORCE
- Ogling	- Requests for dates	- Love letters	- Violating space	- Relationships	- Quid pro quo	- Rape
- Staring	- Questions about personal life	- Obscene letters	- Patting/grabbing	- Using position to request dates, sex, etc.	- Demands	- Physical assault
- Posters	- Lewd comments/jokes	- Cards	- Pinching		- Loss of job	
- Magazines	- Whistling	- Notes	- Carressing		- Selection process	
- Flyers			- Kissing			

**A variety of CONDITIONS**

- Individual perceptions, experiences, and interpretations influence a person's concept of sexual harassment
- Sexually harassing behaviors may or may not be illegal and may range from policy violations to unlawful activity
- Behaviors may be a hostile or "quid pro quo" (something for something) environment
- Can occur between the opposite sex and (or) same sex, depending on the circumstances
- May often occur between peers or coworkers or by supervisors directing behaviors at subordinates
- May occur on or off duty

**A variety of RESOLUTIONS**

- Confront the behavior, talk with the offender, discuss the impact of the behavior, and ask him or her to stop immediately
- Ask another person, coworker, or friend to accompany you to confront the offender
- Document the behavior, including date, time, events, etc.
- Inform your supervisor; ask him or her to intervene or help you get your concerns into proper channels
- Use the chain of command--the primary and preferred channel for identifying and correcting sexual harassment
- Contact your equal opportunity office or other support agency

## ***ATTACHMENT 5: ACRONYMS (i)***

<b>ABU</b>	Airman Battle Uniform
<b>BDU</b>	Battle Dress Uniform
<b>BELPs</b>	Base Expeditionary Leadership Problems
<b>BT</b>	Blue Thunder
<b>CC</b>	Commander
<b>CSJFTC</b>	Camp Shelby Joint Forces Training Center
<b>SDCS</b>	Commander's Support Staff
<b>Cadet FLT/AO</b>	Flight Academics Officer
<b>Cadet FLT/CC</b>	Flight Commander
<b>Cadet FLT/CD</b>	Deputy Flight Commander
<b>Cadet FLT/D&amp;C</b>	Flight Drill & Ceremonies Officer
<b>Cadet FLT/PFO</b>	Flight Physical Fitness Officer
<b>Cadet FLT/STANDO</b>	Flight Standardization Officer
<b>Cadet GP/AO</b>	Group Academic Officer
<b>Cadet GP/CC</b>	Group Commander
<b>Cadet GP/D&amp;C</b>	Group Drill and Ceremonies Officer
<b>Cadet GP/PFO</b>	Group Physical Fitness Officer
<b>Cadet GP/STANDO</b>	Group Standardization Officer
<b>Cadet Sq/CC</b>	Squadron Commander
<b>Cadet Sq/CD</b>	Deputy Squadron Commander
<b>CTA</b>	Cadet Training Assistant
<b>CTQ</b>	Call to Quarters
<b>CV</b>	Vice Commander
<b>D&amp;C</b>	Drill and Ceremonies
<b>DD</b>	Department of Defense (Form)
<b>DM</b>	Dorm Maintenance
<b>FLT/CC</b>	Flight Commander
<b>FT</b>	Field Training
<b>FTAP</b>	Field Training Academic Preparation
<b>FTDG</b>	Field Training Distinguished Graduate
<b>FTSP</b>	Field Training Superior Performer
<b>FTU/CC</b>	Field Training Unit Commander
<b>FTU/COC</b>	Field Training Unit Commandant of Cadets
<b>FTU/CV</b>	Field Training Unit Vice Commander
<b>FTU/DO</b>	Field Training Unit Director of Operations
<b>FTU/SD</b>	Field Training Unit Director of Support
<b>FTU/SDA</b>	Field Training Unit Academic Instructor
<b>FTU/SDCS</b>	Field Training Unit NCOIC
<b>FTU/SDL</b>	Field Training Unit Liaison Officer
<b>FTU/SDLG</b>	Field Training Unit Logistics NCO
<b>FTU/SDS</b>	Field Training Unit Scheduling Officer
<b>FTU/SDP</b>	Field Training Unit Project Officer
<b>FTM</b>	Field Training Manual
<b>FTU</b>	Field Training Unit
<b>GLP</b>	Group Leadership Problem

<b>GTR</b>	Government Transportation Request
<b>IAW</b>	In Accordance With
<b>ICT</b>	Individual Cadet Time
<b>MTI</b>	Military Training Instructor
<b>NCO</b>	Non-Commissioned Officer
<b>NCOIC</b>	Non-Commissioned Officer In Charge
<b>NLT</b>	No Later Than
<b>OIC</b>	Officer in Charge
<b>PFR</b>	Performance Factor Rating
<b>PFD</b>	Physical Fitness Diagnostic
<b>PFA</b>	Physical Fitness Assessment
<b>PH</b>	Personal Hygiene
<b>POC</b>	Professional Officer Course
<b>POD</b>	Point of Departure
<b>POV</b>	Privately Owned Vehicle
<b>PT</b>	Physical Training
<b>PTU</b>	Physical Training Uniform
<b>PVC</b>	Professional Values Council
<b>QFR</b>	Qualifying Fitness Review
<b>SDCS</b>	Commander's Support Staff
<b>SDO</b>	Staff Duty Officer
<b>SIE</b>	Self-Initiated Elimination
<b>SP</b>	Superior Performer
<b>TD</b>	Training Day
<b>UOD</b>	Uniform of the Day
<b>WBG</b>	Wet Bulb Globe Temperature

## **ATTACHMENT 6: STANDARDS OF BEHAVIOR (f)**

<b>A. PREPARATION FOR FIELD TRAINING</b>
<b>FIELD TRAINING MANUAL (FTM)/AIRMAN'S MANUAL (ATM) TESTS:</b> Evaluated through scores obtained on FTM/ATM Tests.
<b>INITIAL INTERVIEW:</b> Evaluates reporting in procedures, uniform, image/bearing, and FTM knowledge.
<b>STAND-BY INSPECTION:</b> Evaluates the condition and appearance of quarters and equipment.
<b>OPEN RANKS INSPECTION:</b> Evaluates military bearing and personal appearance.
<b>B. PHYSICAL FITNESS ASSESSMENT</b>
<b>OUTSTANDING:</b> Cadet scores 96.0 or higher on the 1st PFA
<b>EXCELLENT:</b> Cadet scores 90.0- 95.9 on the 1st PFA
<b>SATISFACTORY:</b> Cadet scores 75.0- 89.9 on the 1st PFA
<b>MARGINAL:</b> Cadet scores less than 75.0 on the 1st PFA; note cadets must achieve a score of 75.0 on or about TD-8 to remain in training at the FTU
<b>UNSATISFACTORY:</b> Cadet fails both PFAs.
<b>C. LEADERSHIP SKILLS</b>
<b>PROBLEM SOLVING ABILITY:</b> Evaluates the use of the OODA problem solving process.
<b>COORDINATION, CONTROL, DELEGATING, and DIRECTING:</b> Secures cooperation from group, obtains unified effort; maintains and enforces standards, monitors deviations and takes corrective action; assigns tasks to group, gives authority to accomplish tasks without giving away responsibility; in charge of situation.
<b>DYNAMIC LEADERSHIP:</b> Application of management functions; ability to change leadership styles to meet needs of the situation/personnel.
<b>DISPLAYS INITIATIVE:</b> Takes charge when appointed as leader; looks for opportunities to participate or lead; strives to improve him/herself and his/her team; volunteers to help the team.
<b>PERFORMANCE OF DUTIES:</b> Performs and manages duties during leadership positions (feedback from FTO and FT staff), details, additional duties, classroom preparation/participation; anticipates situations/reacts appropriately; self-sufficient; requires little guidance; prepared for FT activities; sets and enforces standards.
<b>FOLLOWERSHIP/TEAM PLAYER:</b> Dedicated to group goals; supports decisions of superiors; contributes their share to achieve the mission; contributor in class discussions; fosters teamwork.

## D. PROFESSIONAL QUALITIES

**OFFICERSHIP:** Exhibits key aspects of professionalism required of an effective Air Force officer; encompasses Air Force core values. Displays little to no regard for his/her own self gain above others needs, admits mistakes, is humble, respectful, and willing to sacrifice for the benefit of the team; adheres to moral principles and has soundness of character; responsible and vigilant.

**ACCEPTS PERSONAL RESPONSIBILITY:** Thinks and acts intelligently without waiting to be prompted; responsible for results of his/her own actions and those of subordinates.

**ATTENTION-TO-DETAIL/SITUATIONAL AWARENESS:** Ability to correctly accomplish tasks according to instructions; ability to recognize changes in environment and act appropriately.

**MOTIVATES OTHERS:** Ability to inspire others to perform to their best ability; sets the example and strives to achieve the same from others.

**TACT/SENSITIVITY:** Ability to relate and interact positively and appropriately in diverse groups of people and a multitude of environments; fair and objective; knows when to be assertive.

**ATTITUDE:** Positive about difficult tasks; constantly strives to improve; strong self-image, enthusiastic.

**HUMAN RELATIONS:** Self-confidence in group dynamics; reacts objectively; makes a genuine effort to maintain and improve working relationships with others.

## E. COMMUNICATION SKILLS

**VERBAL/WRITTEN:** Command of language and grammar, pronunciation and enunciation.

**CLEAR AND CONCISE:** Communicates ideas/thoughts in an organized fashion.

**ARTICULATE:** Speaks/writes in an effective, professional manner.

**CONFIDENT:** Exhibits positive self-image, poised under pressure, ability to project command presence.

## F. JUDGEMENT AND DECISION MAKING SKILLS

**TIME MANAGEMENT:** Effectively executes a multitude of tasks.

**REACTION TO COUNSELING:** Reacts objectively to criticism without getting emotional; shows interest in feedback and strives to improve.

**USES RESOURCES EFFECTIVELY/EFFICIENTLY:** Ability to utilize personnel and equipment appropriately in situational environment; no wasted efforts.

**LEARNS FROM MISTAKES:** Shows dedication to improve actions, behavior, and attitude; makes efforts to prevent similar mistakes.

## G. WARRIOR ETHOS

**ADAPTABILITY TO CHANGE/STRESS:** Seeks new, improved ways to perform tasks; anticipate and plans for change; responds quickly and effectively to crisis, thrives on the training environment; seeks ideas to improve things and performance; challenged by and overcomes adversity.

**APPLIES TRAINING TO AUSTERE ENVIRONMENT:** Demonstrates FTM, ATM, AEF skills knowledge, leadership in field conditions.

**EXPEDITIONARY SKILLS ADAPTABILITY:** Ability to transition from in-garrison to field conditions while employing AEF skills and readiness training.

## **AUTOMATIC MARGINAL/UNSATISFACTORY RATINGS**

### **PREPARATION FOR FIELD TRAINING**

Failure of FTM or ATM test results in no higher than a satisfactory rating.  
Failure of both exams results in no higher than a marginal rating.

### **DRESS AND APPEARANCE/HEIGHT AND WEIGHT STANDARD**

Failure to arrive and remain in compliance with any standards in AFI 36-2903, including rules governing piercings, brandings, tattoos, etc. will result in a score no greater than marginal in Preparation for Field Training.

Overweight/BMI/Body Fat standards upon arrival at FT will result in an unsatisfactory in Preparation for Field Training.

### **PHYSICAL FITNESS ASSESSMENT:**

Failure of first PFA will constitute a Physical Fitness Assessment rating of no greater than marginal.

Failure to pass second PFA will result in an unsatisfactory rating.

### **JUDGMENT AND DECISION MAKING:**

POV travelers who arrive late to FT will receive a score no greater than marginal.

*ATTACHMENT 7: DRILL EVALUATION (f)*

**During the Flight Drill Competition, cadets may see any of the following commands.**

Fall In

About Face

Flight Halt

Column Right/ Left

Left/Right Face

To the Rear

Half Step

Right/ Left Flank

Change Step

Present/Order Arms

Mark Time

Parade Rest

Dress Right, Dress



**AIR FORCE MISSION (k):**

TO FLY AND FIGHT AND WIN... IN  
AIR, SPACE, AND CYBERSPACE

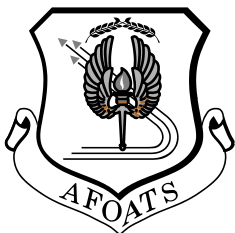

**HOLM CENTER MISSION (k):**

DEVELOP THE BEST AIR FORCE  
LEADERS AND CITIZENS OF  
CHARACTER, DEDICATED TO  
SERVING THE NATION.



**AFROTC MISSION (k):**

TO DEVELOP QUALITY LEADERS  
FOR THE AIR FORCE.

THIS PAGE INTENTIONALLY LEFT BLANK



*Remember those who  
fought for you...*